

# WITT Monitoring of pointing machine - Predictive Maintenance -

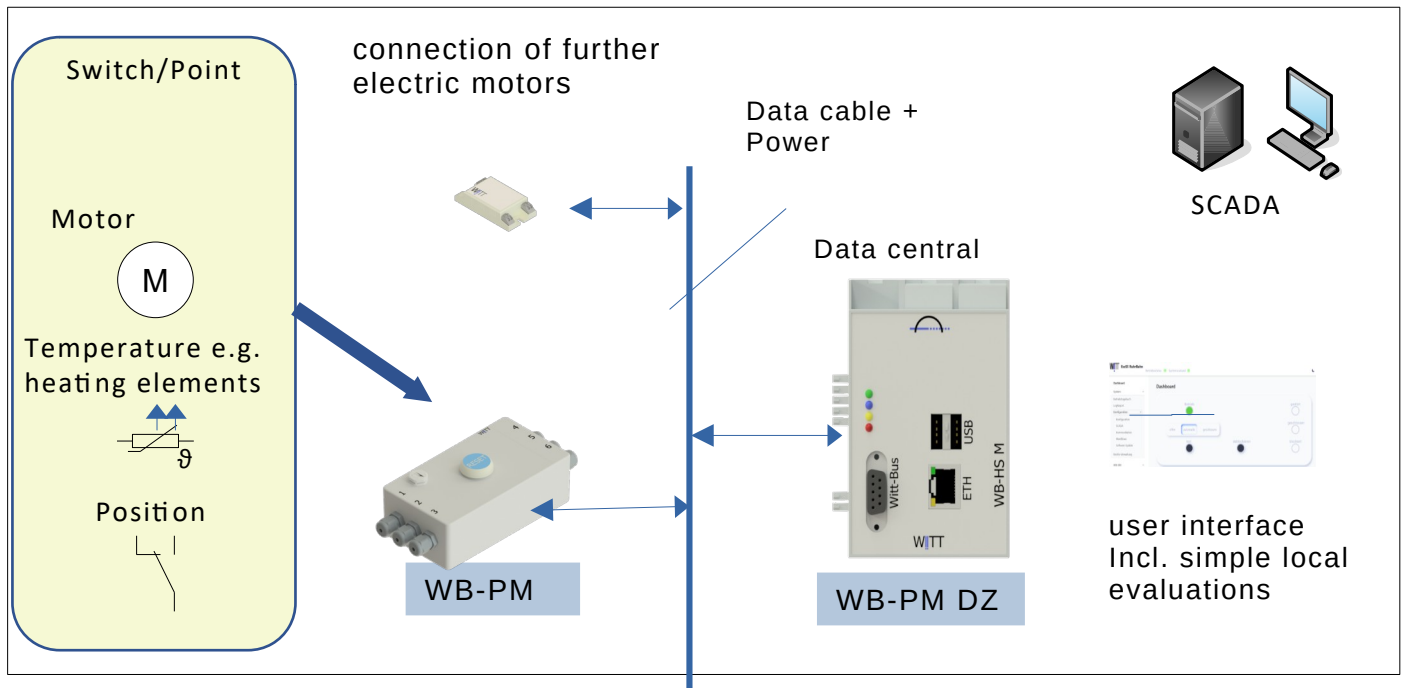

## Usage

The WB-PM in combination with the "WB-PM DZ" data center is used for the systematic determination of physical and electrical variables for assessing the system status of an electrically driven switch.

The data determined enables you to carry out predictive maintenance, since the condition of the system can be determined using the measurement results and predictions can be made, for example with regard to wear and tear. This leads to an avoidance of unforeseen failures. In addition, maintenance plans can be better planned. The system provides you with detailed information without complicated installations and without changes relevant to approval. It is therefore ideal for retrofitting existing systems.

## Description

The system also consists of at least two components: the WB-PM and the WB-PM DZ. If required, the system can be expanded with a SCADA system.

The WB-PM is installed in the immediate vicinity without changing the existing electronics on the existing motor of the electric points drive. The WB-PM constantly determines measurement data from the connected units and makes an initial evaluation of the measurement data. Measurement data is transmitted to the WB-PM DZ via cable or optionally "over the air". The WB-PM DZ collects the measurement data from the connected WB-PM and transmits them to a SCADA system for long-term storage and evaluation.

The intuitive user interface of the WB-PM DZ enables the user to easily configure the entire system. The user can query the current status of the individual WB-PM in order to support work on the infrastructure or service work on site.

Integrating these components into your SCADA system is easy and can be carried out by WITT Solutions GmbH. The advantage of integration is that it enables mass storage or the detection and evaluation of long-term cycles of the system. It is possible to purchase a library for evaluating the engine condition.

## Function

The autonomous measuring unit WB-PM determines measured variables using individually adapted sensors and additional parameters. The data acquisition takes place with different frequencies (rest phase/activity). The pre-evaluation focuses on exceeding critical values. This and the measured values re transmitted to the WB-PM DZ. Depending on the selected options or functions of the WB-PM DZ, the measurement data can be buffered, visualized and evaluated as a communication buffer.

## Technical data „WB-PM DZ Data central“

supply voltage	60 VDC – 240VAC / 50Hz
operating environment	0 – +30 °C not condensing
Kommunikation to SCADA	On demand
power consumption	Approx. 60W
weight	0,2Kg
casing	DIN rail TE 4
Number of WB-PM in a network	protection class IP20 127 <sup>127</sup>

## Option

Item number		
	Mass data storage SSD	250GB
	Mass data storage SSD	500GB
	Mass data storageSSD	1 TB
	WB-MC Different protocols	On demand
	Communication Wired	On demand
	6 wireline (incl. power supply to WB-PM)	
	Communication „Over the Air“	On demand

## Technical Data „WB-PM Pointing Maschine“

supply voltage	24VDC
	Via data line
power consumption	5W
protection class	IP65
connection	common IoT protocols
weight	0,2Kg
Dimensions (W × H × D)	100 x 60 x 30

## Captured measurement data

Flexible measuring range, which is designed individually depending on the motors and heating used.

engine temperature	-40 + 200 °C
current from the engine	Typical +- 200A
Voltage measurement for the motor left / right	0 VDC +- 400VDC / 0 VAC +- 280VAC (dielectric strength to 1000VDC)
voltage of the heater	0 VDC +- 400VDC / 0 VAC +- 280VAC (dielectric strength to 1000VDC)
Current measurement of the heater	Up to 80 A
Temperature range of the heaters	-40 + 200 °C
Number of temperature sensors	4
humidity	0 to 100%
ambient temperature	- 30 + 75 °C
Position check by end stop	auxiliary contact

## Measurement data and optional evaluation

The components WB-PM and WB-PM DZ collect measurement data and make them available for evaluation, e.g. for a SCADA system.

There are two basic interpretations here:

### 1.) Event:

Here an action is requested by the interlocking. The movement is e.g. through an obstacle such as ice or similar only possible with a different energy expenditure. Can this be recognized directly by the WB-PM and escalated immediately by the internal protocol based on priorities.

### 2.) Statistical

The system collects measurement data and evaluates this or its change per movement.