



CREATIVE INNOVATIONS...CONTINUING TRADITION

PowerRail, Inc.
205 Clark Road
Duryea, PA 18642
Phone: 570-883-7005
Email: Sales@ePowerRail.com

Uniting Innovation, Engineering, Manufacturing, and Distribution

Light Rail Solutions

PowerRail, an AAR M-1003 Certified Quality Company, proudly offers Light Rail Parts and Components.

Whether the part is obsolete, hard to find, or requires enhancing for reliability, PowerRail is here to help. Our Engineering Staff is experienced in design and development to help find a solution for you.

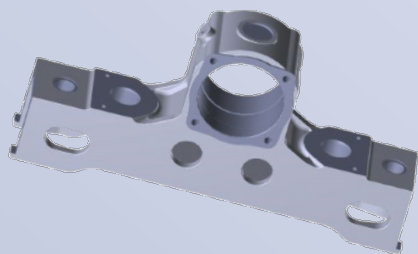

Obsolete CAF Timken cast/machined axle box manufactured in-house by PowerRail

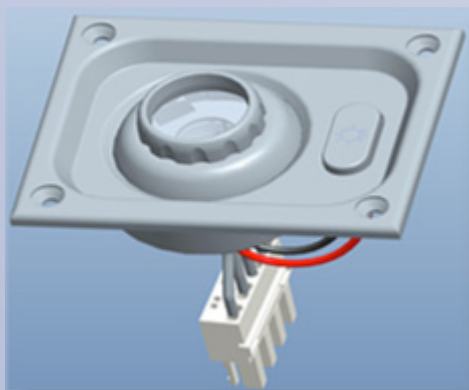

LED Circuit Board Technology for Reading Lights, Specialty Lights and Upgrading from Incandescent to LED

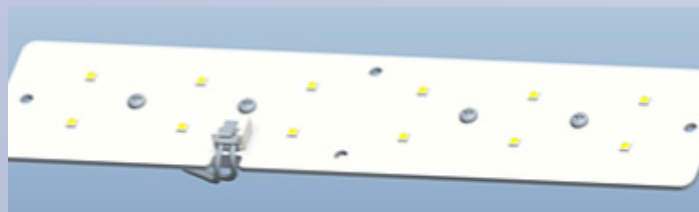
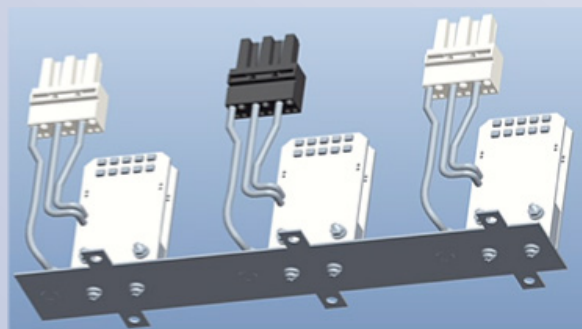

www.ePowerRail.ComTM

T-8 LED Tube Lighting

LED Cab Tube Upgrades for all Passenger Cars.

- Latest Technology
- Less re-wiring
- Long Life Cycles

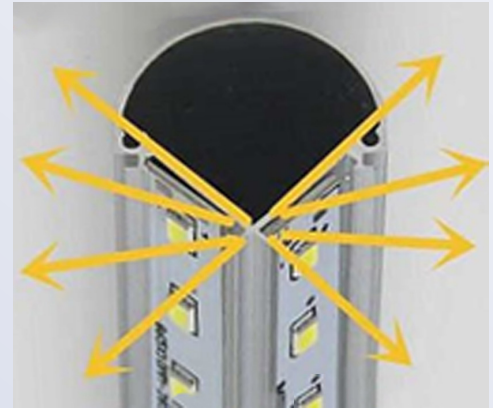

32,000 BTU Modular Design Air Conditioner

NO Inverter needed. Reliable, brushless system. Modular design allows for easy operations during maintenance with reduced labor costs and limited downtime.

Condenser



Compressor - 74V
Brushless Motor
NO Inverter!

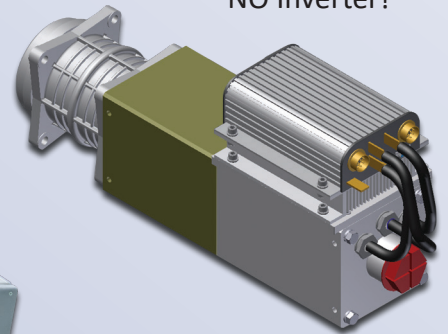

32,000 BTU Evaporator - Air Handler



Also Available

- Roller Bearings — New & Remanufactured
- Sensitive edge door rubber
- Sealing Solutions, Gaskets, O Rings, Rubber Products
- Shocks/Dampeners (motor truck/center truck)
- Conical springs
- Chevrons
- Voltage regulators — New and Remanufactured
- Contactors
- Electric traction replacement parts
- Composite flooring
- Non-skid safety solutions

