



CONNECT AND PROTECT

FIRE-RATED THREE-WAY SPLICE (FTS) SYSTEM

nvent

PYROTENAX



PYROTENAX

Tunnel lighting systems need a fully approved fire-rated three-way splice solution

Emergency lighting systems within road and rail tunnels must remain functional during a fire event as per the requirements of NFPA 130 and 502 standards. The FTS system protects the primary main power line leading to and from the fire zone, and due to its fused design, will not be interrupted with a failure in a single light branch circuit.

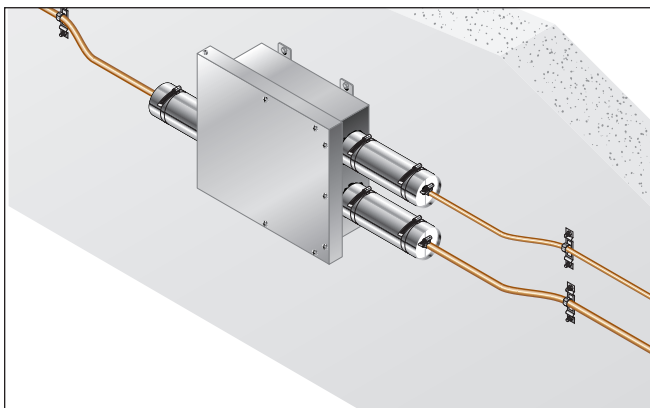

HOW IT WORKS

The FTS splice system protects the primary main power line leading to and from the fire zone. Should a single light be consumed by fire, its branch line's dedicated fuse within the FTS box would blow, but the remaining branch line and main power line would remain intact and continue to operate.

The FTS system is offered primarily as a custom pre-assembled system with pre-terminated cables for both the main power and branch circuits. If installers would prefer to terminate the cables on site, FTS termination kits can be purchased separately.

The pre-assembled system option is designed to optimize the installation time and minimize both labor costs and tunnel down time during system installation.

nVent PYROTENAX System 1850 Cable keeps power flowing during a fire Pyrotenax MI cable not only survived the Chunnel (UK) fire, it was used to power equipment during the clean-up.



ABOUT PYROTENAX MI CABLE

- Completely inorganic construction – Magnesium Oxide and Copper
 - zero smoke
 - zero flame spread
 - zero fuel contributed
- Smaller diameter cable
- Smaller bend radius
- High tensile strength issues
- Ampacity advantages
- The first 2 hour UL/ULC listed fire-resistant system
- Uncontested electrical performance at high temperatures
- Exceptional cable life, longest warranty in the industry
- UL listed factory and field assembled 2-way splices available
- No conduit required
- Can be supplied with an LSZH Jacket
- Can be installed in Stainless Steel Cable Tray

APPROVALS

System 1850 Cables:



Terminations for System 1850 Cables:



Electrical Enclosure:



Completed Splice:

- Splice is part of the Electrical Circuit Integrity System (FHIT) System No. 1850 in the UL Fire Resistance Directory when used with UL Classified System no. 1850 cable
- Splice is part of the Electrical Circuit Integrity System Certified for Canada (FHIT7) System No. 1850 in the ULC Fire Resistance Directory when used with ULC Listed System no. 1850 cable (tested with hose stream)



UL Classified, 1-hour fire-resistive cable, tested to UL 2196



ULC Listed, 1-hour fire-resistant cable, tested to ULC-S139

North America

Tel: +1.800.545.6258
Fax: +1.800.527.5703
Tel: +1.650.216.1526
Fax: +1.650.474.7711
thermal.info@nvent.com

Our powerful portfolio of brands

CADDY

ERICO

HOFFMAN

RAYCHEM

SCHROFF

TRACER



All nVent marks and logos are owned or licensed by nVent Services GmbH or its affiliates. All other trademarks are the property of their respective owners. nVent reserves the right to change specifications without notice.

© 2018 nVent. Pyrotenax-SB-H60221-FireRateThreeWaySplice-EN 18/05

nVent.com/Pyrotenax