



---

# Users Manual

46" Exterior Digital Public Information Display System Monitor (PIDS)

---

Model Number: NISSM-460LH

---

*Please read through this manual for proper safety instructions before installing this product.*

# *Table of Contents*

---

	<u><i>Page #</i></u>
<i>1.0 WARRANTY INFORMATION</i>	<i>03</i>
<i>2.0 PRODUCT OVERVIEW</i>	<i>04</i>
<i>3.0 LCD SPECIFICATIONS</i>	<i>05</i>
<i>4.0 MAINTENANCE DOOR</i>	<i>06</i>



## **CAUTION**

If you fail to comply with the regulations for safety and proper use, damage or injury may be caused. Out of warranty.

# 1.0 Warranty Information

---

## Regarding Operating Conditions

This product should only be installed in an environment that satisfies both the temperature and humidity levels required for normal operating conditions.

Temperature:  $-30^{\circ}\text{C}$  to  $+50^{\circ}\text{C}$

Humidity: 20% to 80%

## Warranty Statement

Subject to the requirements, conditions, exclusions and limitations of the original Limited Warranty supplied with Nanov Display Inc. products, and the requirements, conditions, exclusions and limitations contained herein, Nanov will additionally provide Warranty Repair Service in the world for the warranty period originally specified, and to the Original Purchaser only. The above described warranty repairs must be performed by an Nanov Authorized Service Center or Distributor. Along with this Statement, the Original Limited Warranty Statement and a dated Bill of Sale as Proof of Purchase must be presented to the Service Center or Distributor. Conditions covered are limited only to manufacturing defects in material or workmanship, and only those encountered in normal use of the product.

Warranty – 36 Months

## Notice for Users

This manual describes how to use the product. Please read the manual carefully before using the product. After reading the manual, keep it with the certificate so you may reference the manual at any time. If you have any question or a problem occurs, please contact to the provider or the service center immediately.

## 2.0 Product Overview

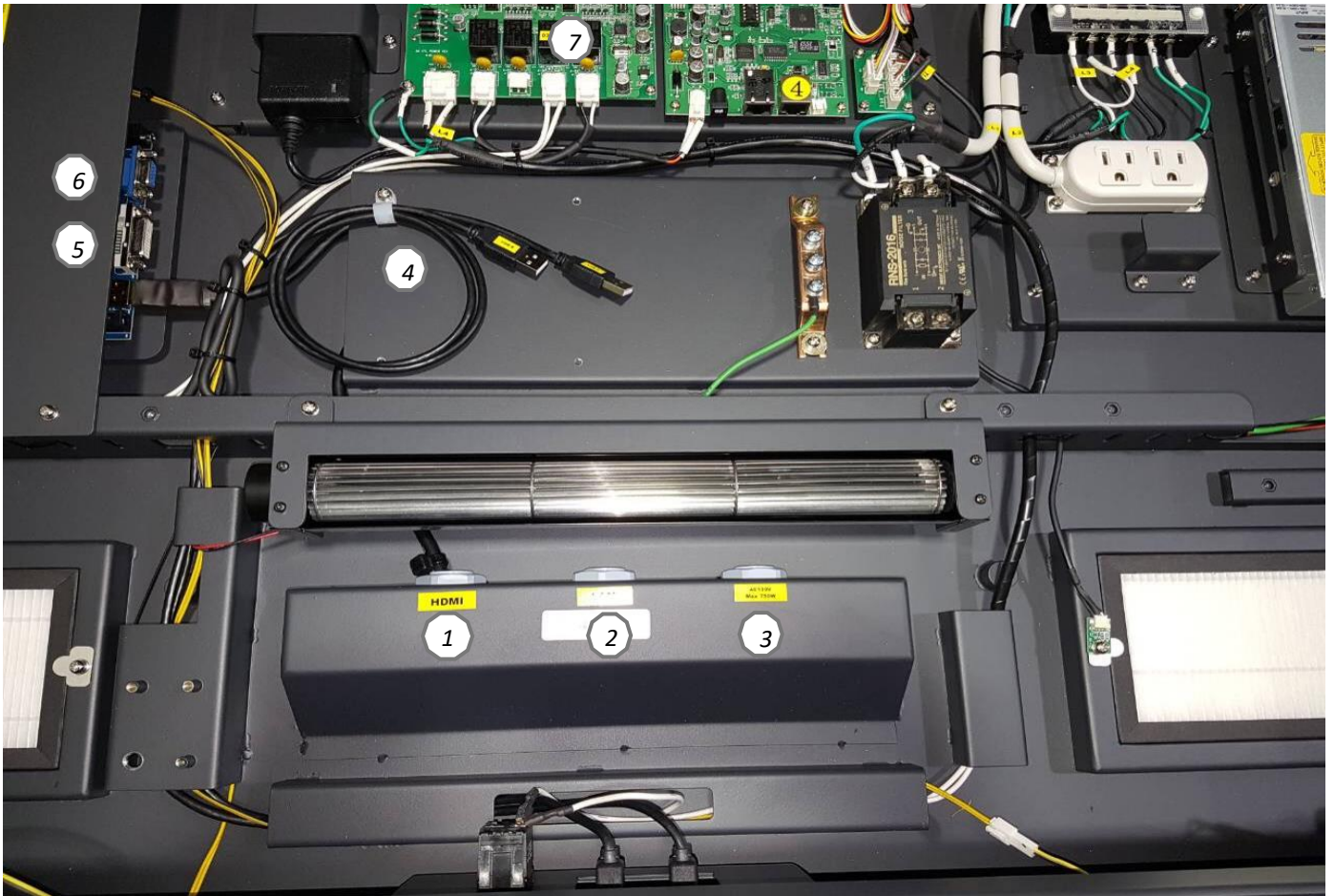

1	<i>HDMI</i>
2	<i>LAN</i>
3	<i>POWER CONNECTOR</i>
4	<i>USB</i>
5	<i>DVI (720p/1080i/1080p)</i>
6	<i>RS-232C</i>
7	<i>Remote Controller Board Set (Main Power)</i>

# 3.0 LCD Specifications

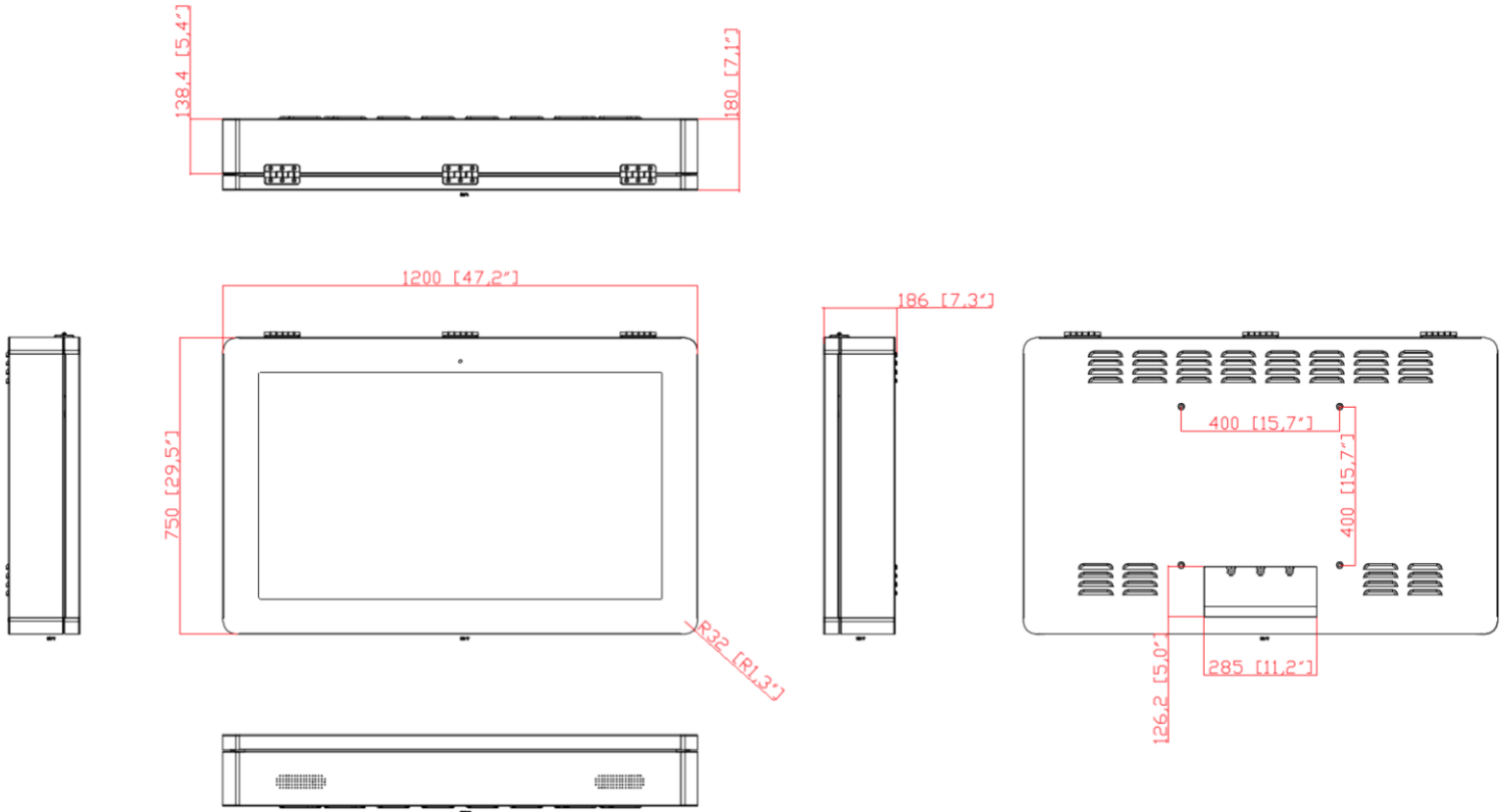

Total System Weight: 60 kg (132 lb.) per unit

# Maintenance Door

---

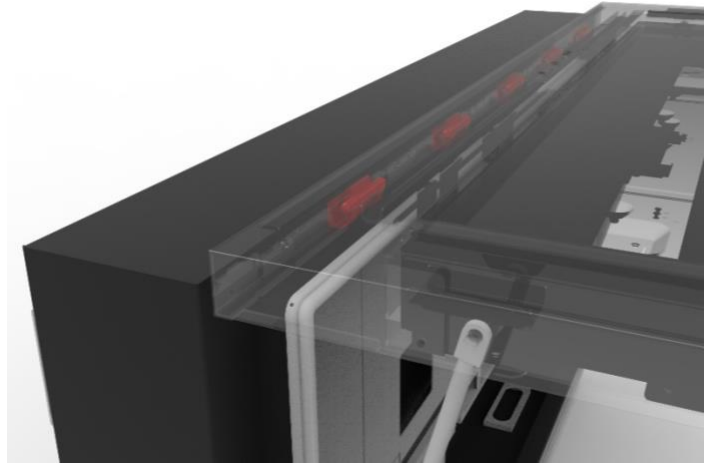
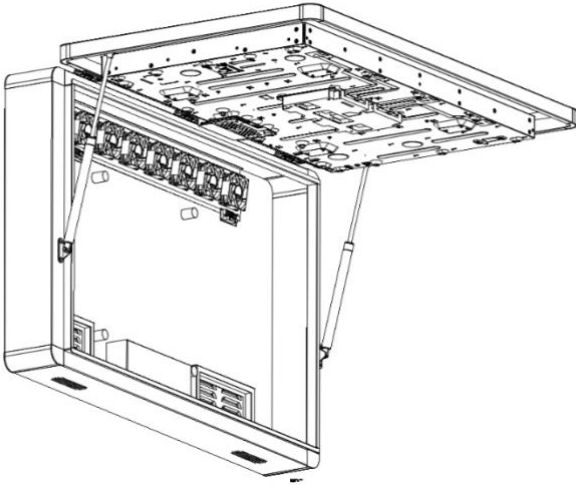

## Contact the Manufacturer

*Nanov Display Inc.*

*3170 Orlando Dr. Unit 2*

*Mississauga, ON L4V 1R5, Canada*

*Tel: (305) 395-6069*

*Fax: (866) 431-7242*