

Advanced Critical Power Solutions for UK Railway Infrastructure

reliable - tough - compact - efficient



The world's most advanced UPS systems for the rail sector



Electronic signalling, emergency lighting, ventilation systems, communication systems, control infrastructure and traffic management, monitoring of equipment, ticketing or passenger information systems all need continually available high quality electrical energy. Other critical loads such as motorised switches and sensitive electrical equipment have also to be protected by a UPS with a high reliability. The Socomec IP+ Rail Range ensures the safe operation of rail networks and infrastructure. Based on the world's most technologically advanced range of critical power equipment, the new IP+ Rail products are housed within a compact, robust steel-framed enclosure – almost twice the thickness of standard UPS cabinets.

The IP+ Rail units are available with IP31 or IP52 ingress protection and anti-corrosion tropicalised circuit boards: this system will operate in harsh environments where conductive dust or dripping water may be present. The electromagnetic disturbance immunity level is double that required by European standards and the internal components meet the strict, low smoke requirements of London Underground and other rail customers.

Life Cycle Support

Socomec provides a complete range of engineering support services – with trackside certified engineers - to handle the Commissioning, Inspection and Maintenance (CIM) of UPS systems throughout their lifecycle. A nationwide network of specialist engineers provides local support 24/7/365 days a year to guarantee operational continuity in the most demanding critical power applications.

With an unrivalled breadth and depth of technical expertise, Socomec can create completely customised CIM packages for your system architecture: customised contract packages give you complete control of

The IP+ Rail is available in a number of versions dependent on the specific application. Power options range from 10 – 120 kVA for three-phase models and 10 – 60 kVA for single-phase models with scalable power and the facility to parallel up to 6 units. Furthermore, the Socomec development team can also customise units to meet your specific requirements.

operating costs and peace of mind throughout hardware life cycle.

Socomec's engineering team will conduct an audit, identifying potential operational continuity risks and assess energy efficiency. A summary report - with costed recommendations - highlights urgent areas plus opportunities for improvement, forming the basis of an optimisation roadmap.

Socomec's Power Quality Audit enables even further investigation helping to optimise the reliability, efficiency and safety of a critical power supply.

IP+ Rail Solutions

- IP+ Rail
- IP+ Rail - Low Smoke Zero Halogen
- IP+ Rail Overhead Line Infrastructure (OLI)
- Emergency Lighting UPS

General Purpose UPS Solutions

- Green Power 2.0 - Ultra High Efficiency Transformerless
- MX Range – High Efficiency Transformer Based UPS
- Rectifiers / Battery Tripping Units
- Static Switches
- UPS solutions for Networking



Control & Monitoring Infrastructure UPS - IP+ Rail



Socomec's IP+ Rail is the very latest in UPS technology for the mass transportation sector and has been engineered specifically to provide optimum energy efficiency for high performance critical power applications - in the most challenging operating environments.

Designed for the most demanding applications

Housed in a compact, robust, steel-framed enclosure, the system has IP31 or IP52 ingress protection as well as anti-corrosion tropicalised circuit boards and a high electromagnetic disturbance immunity level. The system is also available in a version that is LU Section 12 compliant: this uses low smoke, zero halogen components and has surfaces painted in a finishing system compliant with London Underground specifications for use in sub-surface stations. The IP+ Rail range is the first UPS system to attain a London Underground Product Registration Certificate No: 1492

Easy integration into electrical infrastructure

- Input power factor > 0.99 and input current harmonic distortion < 3% thanks to IGBT rectifier.
- Galvanic isolation on input and output.
- Compatible with Open Vented Lead Acid, Valve Regulated Lead Acid (VRLA) and Nickel Cadmium batteries.
- User-friendly multilingual interface with graphic display.
- Flexible communication boards for every industrial communication need: dry contacts, MODBUS, PROFIBUS, etc.
- Fully compatible with generator sets.

Process continuity

- Frontal access for input/output cabling, spares replacement and preventative maintenance.
- Scalable power and high availability (using redundancy), with the facility to parallel up to 6 units.

For non-linear/unbalanced loads

- 100 % non-linear loads.
- 100 % unbalanced loads.
- 100 % "6-pulse" loads (motor speed drivers, welding equipment, power supplies...).
- Motors, lamps.

Standard electrical features

- Dual input mains.
- Galvanic isolation transformer.
- Internal maintenance bypass.
- Backfeed protection: detection circuit.
- EBS (Expert Battery System) for battery

Socomec's specialist engineering team has the necessary trackside training and accreditations to install and support your equipment throughout its lifecycle.

Key Benefits

Full Range 10-80 kVA

IP Protection Degree : IP31 standard

Coated Electronic Boards

High Efficiency

Full Galvanic Isolation

Very Compact Unit

London Underground Product Registration Certificate No: 1492

Technical data

MASTERYS IP+ Rail 10-80

Sn [kVA]	10	15	20	30	40	60	80
Pn [kW] - 3/1	9	13.5	18	27	32	48	-
Pn [kW] - 3/3	9	13.5	18	27	36	48	64
Parallel configuration ⁽¹⁾	Available up to 6 units for power extension or redundancy						
Efficiency	Up to 95% in VFI –SS-11 mode TÜV verified (transformer excluded)						
INPUT							
Rated voltage	400 V						
Voltage tolerance	± 20% ⁽³⁾ (up to -40% @ 50% of rated power)						
Rated frequency	50/60 Hz						
Frequency tolerance	± 10%						
Power factor / THDI ⁽²⁾	0.99 / < 3%						
OUTPUT							
Rated voltage	1ph+n/2ph 230(220/240 configurable) ⁽³⁾ 3ph + N: 400 V (380/415 V configurable) ⁽³⁾						
Voltage tolerance	± 1%						
Rated frequency	50/60 Hz						
Frequency tolerance	± 2% (configurable from 1% to 8% with generator set)						
Total output voltage distortion - linear load	< 1%						
Total output voltage distortion - non-linear load	< 5%						
Overload	125% for 10 minutes, 150% for 1 minute						
Crest factor	3:1 (complying with IEC 62040-3)						
Power factor without derating	From 0.6 lagging up to 0.9 leading						
BYPASS							
Rated voltage	1ph + N: 230 V, 3ph + N: 400 V						
Voltage tolerance	± 15% (configurable from 10% to 20% with generator set)						
Rated frequency	50/60 Hz						
Frequency tolerance	± 2% (configurable from 1% to 8% with generator set)						
ENVIRONMENT							
Operating ambient temperature	from 0 °C up to +40 °C (from 15 °C to 25 °C for maximum battery life)						
Relative humidity	0% - 95% without condensation						
Maximum altitude	1000 m without derating (max. 3000 m)						
Acoustic level at 1 m (ISO 3746)	< 52 dBA < 55 dBA < 65 dBA						
UPS CABINET							
	up to 20kVA	30kVA	40kVA	60kVA	80kVA		
Dimensions (3/1) wxDxH Transformer included	600x800x1400 mm			1000x835x1400 mm		-	
Dimensions (3/3) wxDxH Transformer included	600x800x1400 mm				1000x835x1400 mm		
Weight (3/1)	230 kg	250 k	270 kg	330 kg	490 kg	540 kg	-
Weight (3/3)	230 kg	250 kg	270 kg	320 kg	370 kg	500 kg	550 kg
Degree of protection	IP31 and IP52 as option (according to IEC 60529) Coated electronic boards ⁽⁴⁾						
Colours	RAL 7012						
STANDARDS							
Safety	EN 62040-1 (TÜV SÜD certified), EN 60950-1, LU 1-085 (Section 12 LU) ⁽⁴⁾						
EMC	EN 62040-2 (2nd Edition)			G-222	EN 50121		
Performance	EN 62040-3 [VFI-SS-111]						
Product declaration	CE						

1) With transformer on input/bypass side. (2) For source THDV < 2 % and nominal load. (3) Three-phase 220-230-240 V from 15 to 40 kVA. (4) Section 12 version units only

Overhead Line Infrastructure (OLI) UPS - IP+ Rail (OLI)



Socomec's IP+ Rail (OLI) offers increased energy availability: the system can take inputs from both a 25 kV overhead line as well as a 400V AC mains supply.

As a result, this solution potentially avoids the need for a diesel generator and its associated maintenance, fuel storage and refuelling costs.

The innovative rectifier stage converts the input voltage into a DC voltage that will charge both the UPS battery and supply the input stage of the inverter.

In normal mode*, the upstream voltage of the rectifier corresponds to the transformed single phase voltage of the overhead line. The transformer and voltage stabiliser eliminates voltage sags and surges related to current draw of locomotives. When this voltage is not present or is no longer within tolerance, it is the 3 phase DNO supply which is sent directly to the UPS rectifier.

The inverter converts the DC voltage, provided either from the rectifier output or from the battery in a perfect sinusoidal voltage distributed to the critical loads.

The UPS is also equipped with an automatic bypass which allows a no-break transfer of the load directly onto the mains supply in case of overload or faults.

An external manual bypass completes the solution to allow for maintenance of the UPS.

Key Benefits

- Full Range 20-120 kVA
- IP Protection Degree: IP31 standard
- High Efficiency
- Coated Electronic Boards
- Full Galvanic Isolation
- External Manual Bypass
- (Low Smoke Zero Halogen option)

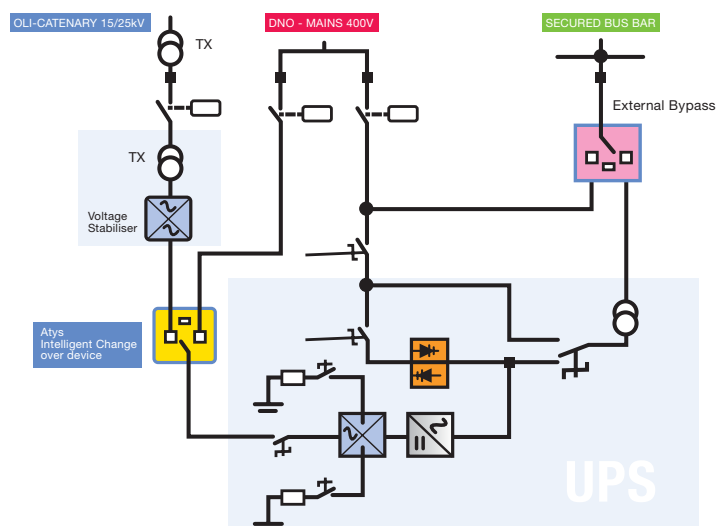

Technical data

MASTERYS IP+ Rail (OLI) 20-120

Sn [kVA]	20	30	40	60	80	100	120
Pn [kW] - 3/1	18	27	32	48	-	-	-
Pn [kW] - 3/3	18	27	36	48	64	90	108
Parallel configuration ⁽¹⁾	Available up to 6 units for power extension or redundancy						
Efficiency	Up to 95% in VFI -SS-11 mode TÜV verified (transformers excluded)						
INPUT							
Rated voltage	230V 1ph+n/2 ph coming from overhead line 400V 3ph+n coming from mains or generator						
Voltage tolerance	± 20% (up to -40% @ 50% of rated power)						
Rated frequency	50/60 Hz						
Frequency tolerance	± 10%						
Power factor / THDI ⁽²⁾	0.99 / < 3%						
OUTPUT							
Rated voltage 3/1UPS	1ph+n/2ph 230(220/240 configurable) ⁽³⁾						
Rated voltage 3/3UPS	3ph + N: 400 V (380/415 V configurable) ⁽³⁾						
Voltage tolerance	± 1%						
Rated frequency	50/60 Hz						
Frequency tolerance	± 2% (configurable from 1% to 8% with generator set)						
Total output voltage distortion - linear load	< 1%						
Total output voltage distortion - non-linear load	< 5%						
Overload	125% for 10 minutes, 150% for 1 minute						
Crest factor	3:1 (complying with IEC 62040-3)						
Power factor without derating	From 0.6 lagging up to 0.9 leading						
BYPASS							
Rated voltage 3/1 UPS	1ph + N/ 2ph: 230 V						
Rated voltage 3/3 UPS	3ph + N: 400 V						
Voltage tolerance	± 15% (configurable from 10% to 20% with generator set)						
Rated frequency	50/60 Hz						
Frequency tolerance	± 2% (configurable from 1% to 8% with generator set)						
ENVIRONMENT							
Operating ambient temperature	from 0 °C up to +40 °C (from 15 °C to 25 °C for maximum battery life)						
Relative humidity	0% - 95% without condensation						
Maximum altitude	1000 m without derating (max. 3000 m)						
Acoustic level at 1 m (ISO 3746)	< 52 dBA	< 55 dBA	< 65 dBA				
UPS CABINET							
	20kVA	30kVA	40kVA	60kVA	80kVA	100kVA	120kVA
Dimensions (3/1) WxDxH	600x800x1400 mm		1000x835x1400 mm		-	-	-
Dimensions (3/3) WxDxH	600x800x1400 mm			1000x835x1400 mm		700x835x1930mm	
Changeover cabinet							
Dimensions W x D x H	800 x 835 x 1930 mm		1000 x 835 x 1930 mm		1600 x 835 x 1930 mm		
Degree of protection	IP31 and IP52 as option (according to IEC 60529) Coated electronic boards						
Colours	RAL 7012						
STANDARDS							
Safety	EN 62040-1 (TÜV SÜD certified), EN 60950-1 LOW SMOKE ZERO HALOGEN CABLES & CABINET COATING						
EMC	EN 62040-2 (2nd Edition) G-222 EN 50121						
Performance	EN 62040-3 [VFI-SS-111]						
Product declaration	CE						

1) With transformer on input/bypass side. - (2) For source THDV < 2 % and nominal load.

Emergency Lighting & Security UPS - Rail CPSS (EN 50171)



- The Rail CPSS (Centralized Power Supply Systems) **EMergency** range is designed and manufactured to protect passengers and staff in the event of a major power failure or incident. The system complies with European safety and fire regulations and is designed and built to be in compliance with EN 50171.
- CPSS provide emergency lighting in the event of a mains failure. The CPSS can also be used to support other emergency systems, such as:
 - automatic fire sprinkler systems
 - emergency detection and warning units
 - smoke extraction equipment
 - carbon monoxide detection systems
 - specific systems for safety-sensitive areas
 - access control systems

Key Benefits

- Main power source compliant with EN 50171.
- Online double conversion technology (VFI-SS-111).
- Suitable for leading loads up to PF 0.9 without derating.
- High capacity batteries with a 10-year life expectancy.
- Batteries with two independent units.
- Manual and automatic battery test.
- Control panel with graphic display.
- LAN interface (Ethernet).
- RS 232 / 485 serial interface.
- Interface with voltage-free contacts.



Advantages of the Rail CPSS **EMergency**

- Mains power source compliant with BS EN 50171.
- Online double conversion technology (VFI-SS-111).
- Suitable for leading loads up to PF 0.9 without derating.
- High capacity batteries with a 10-year life expectancy.
- Batteries with two independent and redundant units.
- Manual and automatic battery test.
- Control panel with graphic display.
- LAN interface (Ethernet).
- RS 232 / 485 serial interface.
- Interface with voltage-free contacts.

Operating Modes

- Changeover mode.
- Parallel stand-by mode.
- Changeover mode with additional control switch for central and partial load switching (on request).
- Non-maintained changeover mode.

Batteries & Battery Chargers

- VRLA (Valve Regulated Lead Acid).
- Long life expectancy: 10 years operating at 20 °C.
- Compliant with EN 50272-2.
- Back-up time between 30 and 180 minutes. Compliant with EN 50272-2 and EN 60146-1-1.
- Recharge to 80% capacity within 12 hours, compliant with EN 50171.
- Low AC ripple currents for maximum battery life, compliant with EN 50171.
- Battery voltage regulated automatically according to temperature.
- Automatic and manual battery test.
- Input switch for mandatory periodic verification of battery back-up time.

Inverter

- Low harmonic distortion (THDU%) on output side.
- Protection against battery polarity inversion, compliant with EN 50171.

Transformers

- Double-wound with safety earth screen, compliant with EN 61558-2-6 (option).

Remote Monitoring: Advanced Dry Contact (ADC) card available depending on the model selected:

- Operating status.
- Battery charge low.
- Battery charger fault.
- General alarm.
- Earth leakage fault.

Local Alarms

- Input voltage out of tolerance.
- Output voltage present.
- Battery mode.
- Battery circuit interrupted.
- Floating voltage fault.
- On battery when mains present.
- Slow discharge pre-alarm.
- Slow discharge protection alarm.
- Charger fault.
- Earth leakage fault (option).

Technical data

Rail CPSS Emergency

Sn [kVA]	10	15	20	30	40	60	80
Pn [kW] - 3/1	9	13.5	18	27	32	48	-
Pn [kW] - 3/3	9	13.5	18	27	36	48	64
Parallel configuration ⁽¹⁾	Up to 1+1 for redundancy						
Efficiency	Up to 95% in VFI -SS-11 mode TÜV verified (transformer excluded)						
INPUT							
Rated voltage	400 V						
Voltage tolerance	± 20% ⁽³⁾ (up to -40% @ 50% of rated power)						
Rated frequency	50/60 Hz						
Frequency tolerance	± 10%						
Power factor / THDI ⁽²⁾	0.99 / < 3%						
OUTPUT							
Rated voltage	1ph + N: 230 V 3ph + N: 400 V (380/415 V configurable) ⁽³⁾						
Voltage tolerance	± 1%						
Rated frequency	50/60 Hz						
Frequency tolerance	± 2% (configurable from 1% to 8% with generator set)						
Total output voltage distortion - linear load	< 1%						
Total output voltage distortion - non-linear load	< 5%						
Overload	125% for 10 minutes, 150% for 1 minute						
Crest factor	3:1 (complying with IEC 62040-3)						
Power factor without derating	From 0.6 lagging up to 0.9 leading						
BYPASS							
Rated voltage	1ph + N: 230 V, 3ph + N: 400 V						
Voltage tolerance	± 15% (configurable from 10% to 20% with generator set)						
Rated frequency	50/60 Hz						
Frequency tolerance	± 2% (configurable from 1% to 8% with generator set)						
ENVIRONMENT							
Operating ambient temperature	from 0 °C up to +40 °C (from 15 °C to 25 °C for maximum battery life)						
Relative humidity	0% - 95% without condensation						
Maximum altitude	1000 m without derating (max. 3000 m)						
Acoustic level at 1 m (ISO 3746)	< 52 dBA	< 55 dBA	< 65 dBA				
UPS CABINET							
Dimensions (3/1) W x D x H	600 x 800 x 1400 mm			1000 x 835 x 1400 mm			
Transformer included							
Dimensions (3/1) W x D x H	600 x 800 x 1400 mm			1000 x 835 x 1400 mm			
Transformer included							
Weight (3/1)	230 kg	250 kg	270 kg	330 kg	490 kg	540 kg	-
Weight (3/3)	230 kg	250 kg	270 kg	320 kg	370 kg	500 kg	550 kg
Degree of protection	IP31 and IP52 as option (according to IEC 60529)						
Colours	RAL 7012						
STANDARDS							
Safety	EN 62040-1 (TÜV SÜD certified), EN 60950-1 LU 1-085 (Section 12 LU) Option						
EMC	EN 62040-2 (2nd Edition) G-222 EN 50121						
Performance	EN 62040-3 [VFI-SS-111] EN 50171						
Product declaration	CE						

1) With transformer on input/bypass side. - (2) For source THDV < 2 % and nominal load.

UPS solutions for General purpose applications

GREEN POWER 2.0

AC Power from 10 to 2400kW - Ultra High Efficiency - Transformerless UPS



Low TCO (Total Cost Of Ownership)

- High Efficiency: 96%
- Full Rated Power: kW = kVA
- Compact Solution

Optimal Load Protection

- Dual Conversion: VFI-SS-111

Flexible Solution

- Up To 8 Units In Parallel
- Modular Or Central Bypass Solution

SHARYS IP

Modular DC power from 15 to 200A, 24-48-108-120V
DC control applications & switchgear tripping

High Reliability

- Robust IP30 Steel Cabinet
- Standard PCB Coating

User Friendly Operation

- Front mimic panel with clear working status indication
- Digital control and monitoring of rectifiers

Easy to Upgrade and Maintain

- Hot swappable rectifier modules
- Easily expandable, flexible solution



Sharys IP Enclosure



Sharys IP System

UPS solutions for General purpose applications

DELPHYS MX

AC Power from 250 to 5400 kVA – High Efficiency – Transformer Based UPS



High Power Static UPS Protection

- maximum power density
- 0.9 output power factor

Maximum Reliability

- Robust Design
- Internal Redundant Components

STATYS

Static Transfer Solution From 32 to 4000A

Supplied by two independent alternative sources, STATYS:

- Provides redundant power supply to mission critical loads
- Increases the power supply availability by choosing the best power supply quality
- Prevents fault propagation
- Allows easy extension and easy infrastructure design, ensuring high availability of the power supply to critical applications
- Facilitates installation and maintenance procedures



Netys RT

1.1 to 11 kVA for IT and Networking Infrastructure

Simple To Install

- IEC input and output connections
- 19 inch rack or stand alone installation

Easy To Use

- No configuration necessary on first startup
- Easy integration into LAN networks or building management systems

Meets Practical Needs

- Online double conversion technology
- Modular battery extension

Socomec SCP (Solutions for Control and Power) Switching and Protection Systems for Rail

The SCP Division of Socomec has an unrivalled reputation in the field of low voltage switching components and protection systems. Our SCP range includes load-break switches, fuse-combination switches, changeover switches, fuse links, electronic control and protection, energy management systems, enclosures and cabinets. Many of these LV switching and protection products perfectly match the demanding requirements of the UK Rail sector.

Applications for SCP components and systems include:

Protection

Fuserbloc, A comprehensive range of high quality fuse combination switches from 20 to 1250 Amp.

- Signalling
- Protection against overload, short circuit
- Local safety isolation
- Robust supply to life safety systems

Power Availability

Sircover and ATyS, A full range of manual and automatic transfer and bypass switches from 16 to 3200 Amp.

- Life Safety, ventilation, sprinkler, lifts, escalators
- Standby power availability
- Alternate supply availability
- Signalling, DNO supply
- Trackside power supplies

Energy Metering, Management, Quality & Efficiency

Countis and Diris, A wide range of high functionality single and three phase active energy meters, power measurement devices and network analysers. Complemented by Vertelis PMS and EMS software.

- L2 compliance
- Sub metering
- Sub billing
- Internal cost allocation
- Energy efficiency & reduction



Fuserbloc Fuse Combination Switches from 20 to 1250A



ATyS Automatic Transfer & Bypass switches from 40 to 3200A



Countis / Diris Metering, Monitoring & Power Quality meters

About Socomec

As a market-focused, independent, global manufacturer with significant R&D capability, Socomec is perfectly positioned to deliver the optimum turnkey solution for your demanding critical power applications.

Founded in 1922, Socomec has an impressive heritage in critical power and today develops and produces the world's most comprehensive range of highly energy efficient UPS equipment. With commercial and engineering operations around the globe, five manufacturing facilities in Europe and production sites in Tunisia, India and China, Socomec manufactures to exacting standards in world-class operating environments.

Socomec is a market leading specialist in the industry and has a track record in ground-breaking innovation. Flexible and responsive, Socomec is firmly committed to the ongoing research and development of technology to support traditional and emerging critical power applications.

With a global network of specialist engineers, Socomec provides the ultimate support – tailored to your needs – in order to ensure optimum energy efficiency and performance. Furthermore, we will work closely with you throughout a project – and throughout a product's lifecycle – to ensure that we deliver the

best solution for your precise requirements on an ongoing basis.

Socomec has its own highly trained engineering team which has the necessary trackside training and accreditation to install and support equipment throughout the product life-cycle.

The business also has a highly experienced projects group which can work with the client's engineering team to optimise system performance and robustness.



SOCOMEK: an independent manufacturer

The benefit of a specialist

Founded in 1922, SOCOMEC is an industrial group with a workforce of 3000 people. Our core business - the availability, control and safety of low voltage electrical networks with increased focus on our customers' power performance.

The culture of independence

The SOCOMEC Group's independence ensures control over its own decision-making, respecting the values advocated by its own family shareholders and shared by its employees. With around 30 subsidiaries located on all five continents, SOCOMEC pursues international development by targeting industrial and service applications where the quality of its expertise makes all the difference.

The spirit of innovation

As undisputed specialists in Electrical breaking technology, mains supply changeover, power conversion and measurement, SOCOMEC dedicates nearly 10% of its turnover to R&D. As a result the Group can achieve its ambition of always being one technological step ahead.

The vision of a specialist

As a manufacturer with complete control over its technological processes, SOCOMEC is quite unlike the more general providers. The Group is constantly improving its fields of expertise in order to offer its clients increasingly customised and appropriate solutions.

A flexible manufacturing structure

Backed by two European centres of excellence (France and Italy), the Group also benefits from competitive production sites such as Tunisia and locations in the major emerging markets (India and China). These sites have all implemented a system of continuous improvement based on Lean Management principles and are therefore in a position to provide high levels of quality and to meet the deadlines and cost requirements expected by customers.

The focus on service

Our manufacturer's expertise naturally extends to a complete range of services designed to facilitate the design, implementation and operation of our solutions. Our service teams have built their reputation on reassuring guidance, flexible skills and reactivity.

Responsible growth

As a Group which is open to all cultures and firmly committed to human values, SOCOMEC promotes employee initiative and commitment. Working relationships are based on the idea of partnerships and respect for shared ethics. Through the company's commitment to achieving harmonious, lasting development, SOCOMEC fully embraces its responsibilities not only towards its shareholders, employees, customers and partners, but also towards society as a whole and its environment. SOCOMEC has been a signatory to the Global Compact since 2003.

The spirit of innovation

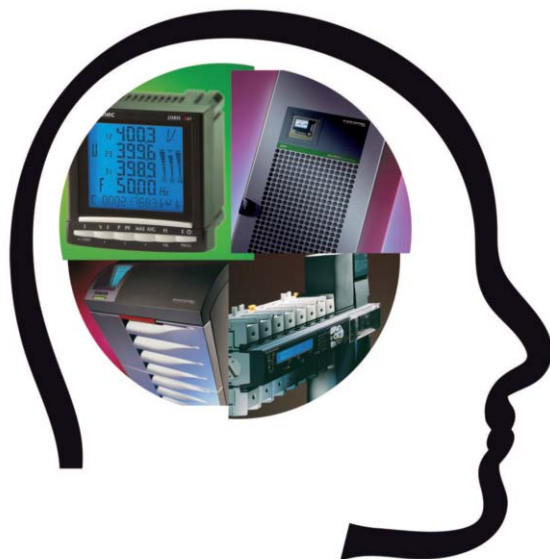

Four key applications: the know-how of a specialist



Critical Power

Ensuring the availability of high-quality power for critical applications.

Thanks to the company's wide range of continuously evolving products, solutions and services, SOCOMEC are experts in the three essential technologies that can ensure the high availability of supply to critical facilities and buildings i.e.:

- uninterruptible power supplies (UPS) that provide high-quality power and reduce distortion and interruptions to the mains supply due to their power storage back-up,
- changeover of high availability sources to transfer supply to an operational back-up source,
- continuous monitoring of installation facilities to prevent failures and reduce operating losses.



Power Control & Safety

Managing power and protecting individuals and property.

SOCOMECS expertise in this domain is unquestionable; the company is an undisputed leader in power switching and changeover functions and has been a specialist manufacturer of electrical equipment since 1922. The company has long defended the benefits of fuse protection for individuals and property and has become a major player in cutting-edge technology such as the monitoring and detection of insulation defects. SOCOMEC guarantees solutions and services which are both relevant and efficient.



Energy Efficiency

Improving building and facility energy efficiency.

SOCOMECS solutions, ranging from sensors to the wide choice of innovative, modular software packages, are driven by experts in energy efficiency.

They meet the essential requirements of managers or operators of tertiary, industrial or local authority buildings, and make it possible to:

- measure power consumption, identify sources of excess consumption, and raise occupant awareness,
- limit reactive energy and prevent associated tariff penalties,
- use the best tariffs, check supplier invoicing and accurately distribute energy bills amongst consumer entities.



Solar Power

Guaranteeing the safety and durability of photovoltaic (PV) facilities.

As experts in the solar energy equipment field, SOCOMEC has all the specialist know-how for implementing key strategic functions in PV facilities, including:

- safety, through specially designed switch disconnectors to cut the DC current generated by solar panels regardless of the facility configuration and operating conditions,
- the reliability of DC facilities thanks to solutions preventing the degradation of insulation and electric arc failure in DC current,
- control of very high-efficiency energy conversion, via PV inverters, to transform all energy generated by the solar panels into power to be consumed locally or re-injected into the national grid.

A cutting-edge laboratory

A decisive link

Located at the Company's headquarters in Benfeld (France), the Pierre Siat test laboratory is one of SOCOMEC's main quality pillars: its contribution to the development, qualification and certification phases plays a decisive role in the process leading to the creation of a product or solution.

Global scale

This totally independent laboratory is recognised by the major certification bodies worldwide: a member of the ASEFA⁽¹⁾ and the LOVAG⁽²⁾, it is accredited by COFRAC⁽³⁾, UL (CTDP⁽⁴⁾), CSA (shared certification) and KEMA (SMT / WMT⁽⁵⁾). It also works in partnership with numerous international certification organisations⁽⁶⁾. The quality and safety requirements specific to each country are therefore fully taken into account.

Specialist facilities

With its 100 MVA (I_{dc} 100 kA rms 1 s) short-circuit platform, three 10 kA overload platforms and numerous other test instruments in facilities covering 1500 m², the Pierre Siat laboratory is currently the 2nd French power laboratory. It combines expertise in electricity and mechanics, pneumatics and computing.

Ongoing commitment

To adapt to the increasingly demanding standards and ever more innovative and high-performance products, the Pierre Siat laboratory is permanently extending the scope of its tests, investing whenever necessary in new equipment.

A vast range of tests

The laboratory submits all SOCOMEC products and solutions (including those in enclosures) to numerous tests in the following fields:

- functional: component resistance and operating tests,
- dielectric: immunity to interference, dielectric insulation, overvoltage, overcurrent,
- mechanical: endurance and mechanical shocks, etc.,
- environment: functional or electrical tests under extreme conditions (temperatures, salt spray, etc.), vibrations.
- AC/DC endurance: in operation and under controlled temperatures (arcs, LV / HV power cuts, etc.),
- temperature rise,
- electromagnetic compatibility (EMC),
- metrology,
- safety: flammability, etc.

Conducted during the design and production phases, these tests guarantee the long-term reliability of the equipment sold.

Customised services

These test facilities and expertise are also available to our partners who require assistance with the qualification and certification of their products or equipment.



We issue certificates of conformity and performance declarations upon request.

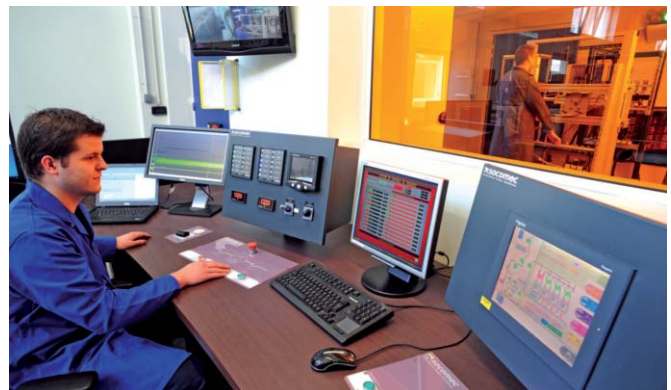

CORPC 342 A

Test platform of the Pierre Siat test laboratory with 8440 kVA transformers



For more information, visit our web site:
www.socomec.fr/laboratoire-essais_fr.html

- (1) Association des Stations d'Essais Françaises d'Appareils électriques basse tensio (French association of low voltage electrical equipment test stations)
- (2) Low Voltage Agreement Group
- (3) Comité Français d'Accréditation (French accreditation body)
- (4) Client test data programme
- (5) Supervised Manufacturer's testing / Witnessed manufacturer's testing
- (6) KEMA, CEBEC, UL, CSA, ASTA, Lloyd's Register of Shipping, Bureau Veritas, BBJ-SEP, EZU, GOST-R, etc.

Why should you choose SOCOMECEC?

“An independent partner working closely with you”

A comprehensive range

A complete and extensive range incorporating hardware, software and specialist services from one source.

A leader in Energy & Power Management

Measurement is the key link in managing an energy efficient project. With the COUNTIS and DIRIS ranges, SOCOMECEC has developed one of the most advanced multi-function measurement ranges on the market, dedicated to improving your energy performance.

High quality and high performance ranges

The DIRIS range is compliant with the latest IEC 61557-12 standard dedicated to multi-measurement devices (PMD*). The COUNTIS range complies with the requirements of the latest MID** directive (B+D module).

Enhanced skills and expertise in Energy Management Software development

With the acquisition of VERTELIS, a leader in web based energy efficiency solutions with over 20 years of experience, SOCOMECEC can now propose a global and high-performance offer, from the current transformer to comprehensive multi-site energy management software.

The services of a specialist, the support of a partner

Consultancy, assistance with commissioning, technical interventions, professional training and more: the experts at SOCOMECEC can support you in improving your energy efficiency objectives and to reach your goals.

* PMD: Performance Measuring and monitoring Devices.

** MID: Measuring Instruments Directive.



Socomec UK contacts

Socomec UPS Cirencester

Units 7A-9A Lakeside Business Park, Broadway Lane, South Cerney, Cirencester, GL7 5XL UK

Tel: +44 (0) 1285 863300 | Fax: +44 (0) 1285 862304 | rail.ups.uk@socomec.com | www.socomec.com

Socomec UPS London

Central Court, 25 Southampton Buildings, London WC2A 1AL UK

Tel: +44 (0) 2034 275107 | Fax: +44 (0) 2030 438889 | rail.ups.uk@socomec.com | www.socomec.com

Socomec SCP Hitchin

Knowl Piece, Wilbury Way, Hitchin, Hertfordshire, SG4 0TY

Tel: +44 (0) 1462 440033 | Fax: +44 (0) 1462 431143 | info.scp.uk@socomec.com

HEAD OFFICE

Socomec Group

S.A. SOCOMECA capital 11 149 200 € - R.C.S. Strasbourg B 548 500 149

B.P. 60010 - 1, rue de Westhouse - F-67235 Benfeld Cedex

Non contractual document. © 2012, Socomec SA. All rights reserved.

www.socomec.com

