

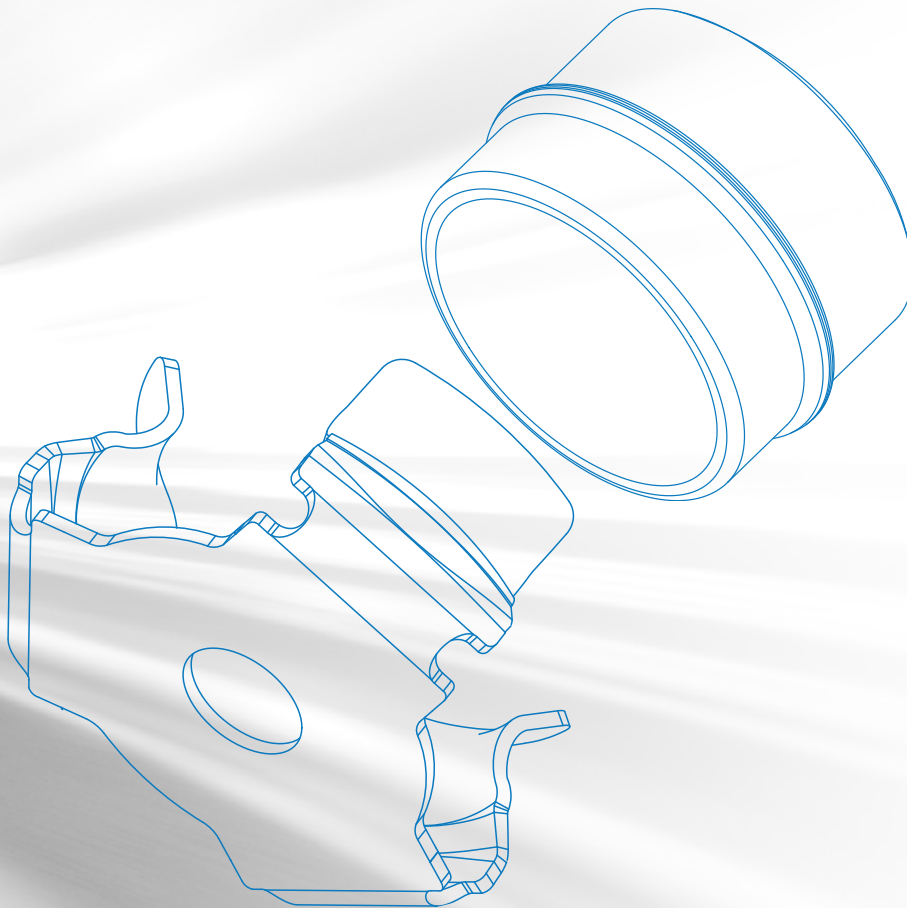

# FAST-CON<sup>®</sup>

SISTEMA DI FISSAGGIO RAPIDO A PRESSIONE IN ACCIAIO INOX  
QUICK PRESSURE FASTENING SYSTEM IN STAINLESS STEEL



PRODOTTI ITALIANI DA SEMPRE | ITALIAN MANUFACTURES SINCE EVER



**specialinsert<sup>®</sup>**  
OUR TRADITION IS TO INNOVATE.



**FAST-CON®** è un sistema brevettato di fissaggio metallico a scatto che permette di collegare rapidamente pannellature e rivestimenti mediante una semplice pressione; l'eventuale rimozione avviene esercitando una lieve trazione del pannello. Il sistema a clip **FAST-CON®** permette di ottenere un fissaggio meccanico a scomparsa rendendo l'unione di 2 elementi rapida e affidabile.

**FAST-CON®** è realizzato da 2 elementi, maschio e femmina, in acciaio inossidabile, con profilo speciale adatto alla connessione rapida fra loro. L'installazione del **FAST-CON®** avviene mediante avvitatura, incollaggio o rivettatura. Le clip prevedono una forza di sgancio (7 kg e 10 kg) che varia a seconda della serie impiegata.

**FAST-CON®** is a patented metal snap fastening system that allows you to quickly connect panels and coverings by simply pressing; any removal occurs by exerting a slight traction on the panel. The **FAST-CON®** clip system allows for a concealed mechanical fixing, making the union of 2 parts quick and reliable.

**FAST-CON®** is made of 2 parts, male and female, in stainless steel, with a special profile suitable for quick connection between them. **FAST-CON®** is installed by screwing, bonding or riveting. The clips have a release force (7kg and 10kg) that varies depending on the series used.

## Applicazioni Applications

Pannellature, controsoffitti, boiserie, rivestimenti asportabili, sedute rimovibili, ante mobili arredo, personalizzazioni desktop pubblicitari, ecc.

*Paneling, false ceilings, boiserie, removable coverings, removable seats, furniture doors, advertising desktop customizations, etc.*

## VANTAGGI/BENEFITS:

- Facile e rapida installazione | *Quick and easy installation*
- Flessibilità di impiego | *Flexibility of use*
- Minimo Ingombro | *Minimum overall dimensions*
- Utilizzabile in ogni settore | *Can be used in every industry*
- Resistente alle fiamme | *Flames resistant*
- Resistente alla corrosione | *Corrosion resistant*
- Lunga durata rispetto ai più comuni sistemi in plastica | *Long-lasting life compared to the most common plastic systems*



Fissaggio a scatto - prodotto brevettato  
Snap fastening system - patented

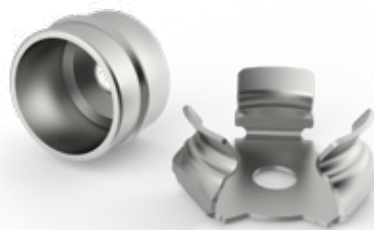

Femmina/Female

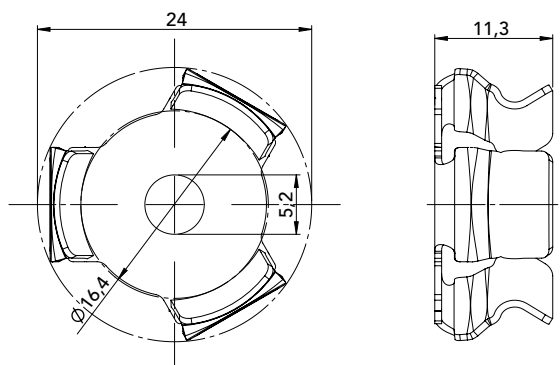

Codice Code	Materiale Material	Carico di Estrazione Extraction Load
<b>FC-01-FE.51</b>	Inox 316 Stainless steel 316	Min 7kg
<b>FC-01-FE.53</b>	Inox 301 Stainless steel 301	Min 10kg

Maschio/Male

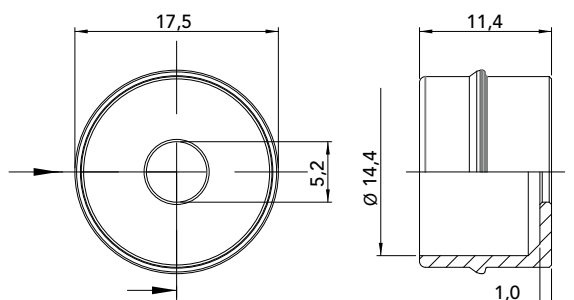

Codice Code	Materiale Material
<b>FC-01-MA.51</b>	Inox 316 Stainless steel 316
<b>FC-01-MA.50</b>	Inox 303 Stainless steel 303

**FAST-CON®** incassato  
Built-in **FAST-CON®**

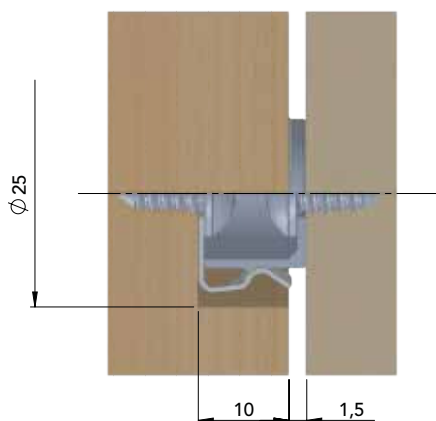

**FAST-CON®** a filo  
**FAST-CON®** flush installation

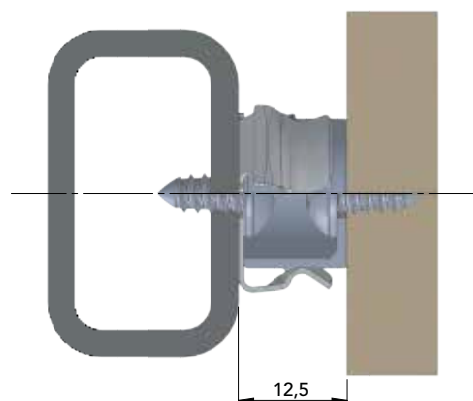

Le dimensioni, espresse in mm, ed i valori relativi al carico di estrazione sono indicativi e non vincolanti.  
Dimensions, expressed in mm, and extraction load values are indicative and not binding.

# GUIDA ALL'INSTALLAZIONE

## Installation guide

Esempio di applicazione: pannello mobile a struttura  
Application example: mobile panel with structure



Vista frontale | Front view



Vista laterale | Side view

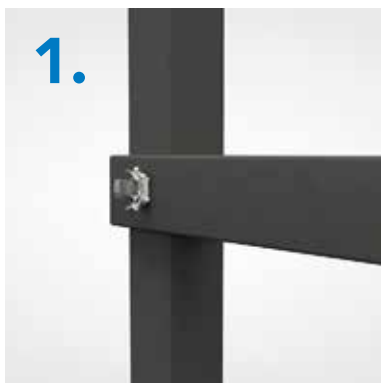

1.

Fissare i **FAST-CON**<sup>®</sup> FC-01-FE.5\_ femmina sulla struttura mediante avvitatura, incollaggio o rivettatura

Fasten the female **FAST-CON**<sup>®</sup> FC-01-FE.5\_ on the structure by screwing, bonding or riveting



2.

Inserire i centrori FC-01-CE.50 nelle clip femmina

Insert the FC-01-CE.50 centering device into the female clips

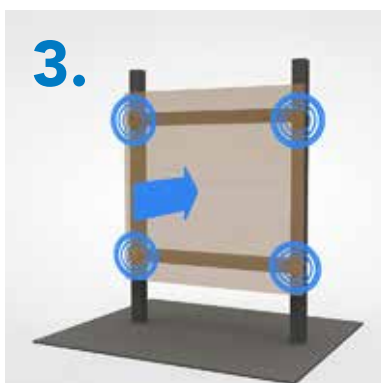

3.

Posizionare il pannello nel punto desiderato ed esercitare una leggera pressione. La marcatura fungerà da riferimento per il fissaggio dell'elemento maschio FC-01-MA.5\_

Position the panel in the desired point and exert slight pressure. The marking will act as a reference for fixing the FC-01-MA.5\_ male part



4.

Fissare l'elemento maschio FC-01-MA.5\_ in corrispondenza delle marcature

Secure the male part FC-01-MA.5\_ at the markings



Guarda il video completo d'installazione/Get a look at the installation guide full video



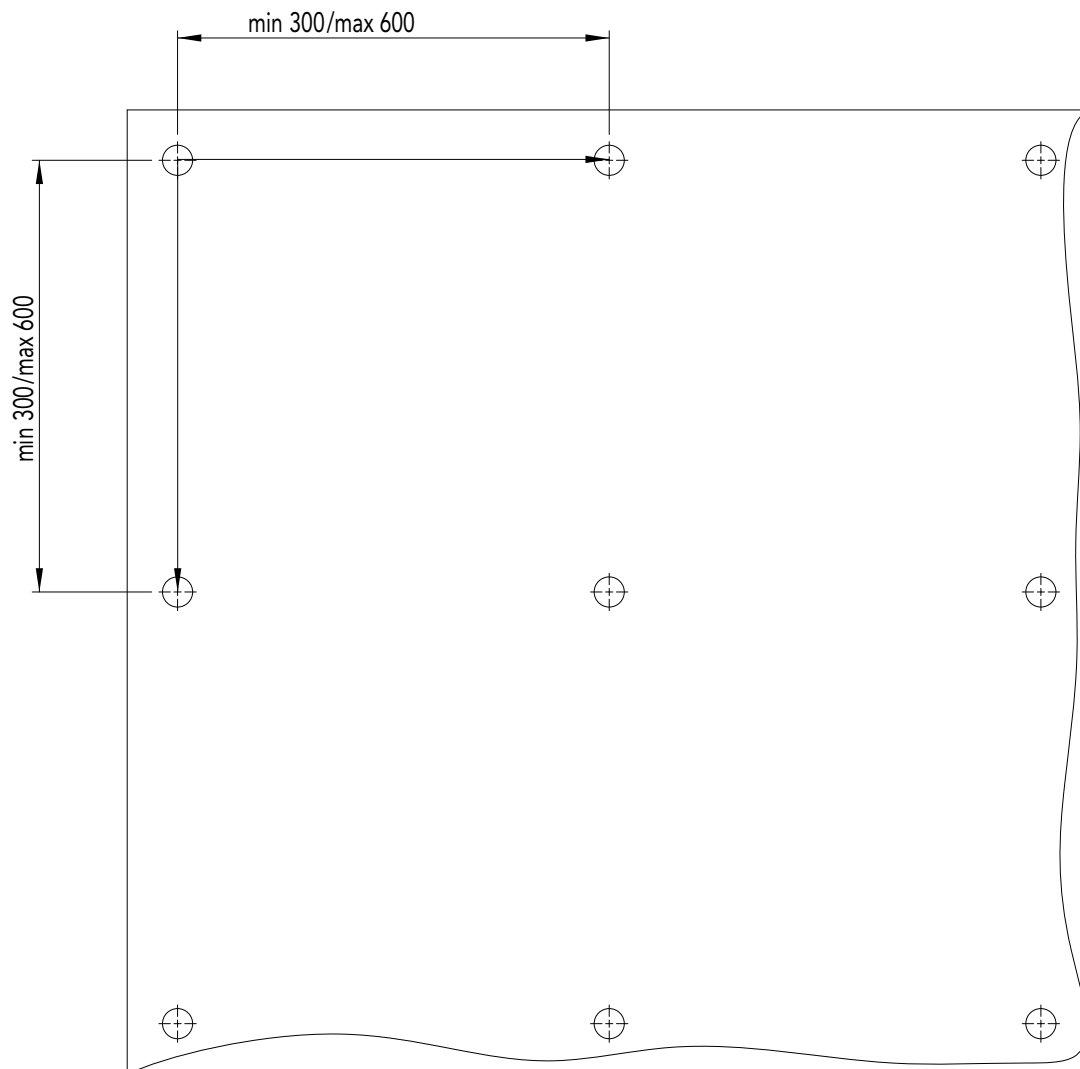

Le dimensioni sono indicative, non vincolanti, espresse in mm. Si consiglia sempre di effettuare delle prove.  
*Dimensions are indicative and not binding, expressed in mm. It is always recommended to carry out tests.*

La distanza dal bordo e l'interasse possono variare a seconda della tipologia d'installazione, della natura del pannello e della struttura.

*The distance from the edge and the center may vary depending on the type of installation, the nature of the panel and the fixed structure.*



# ACCESSORI

## Accessories

**specialinsert**

### FC-00-CE.50

Centratore acciaio inox  
Stainless steel centering device



### FC-00-PR.70

Pinza di ripristino per elemento  
femmina FC-00-FE  
Female FC-00-FE recovery pliers



### FC-00-LE.12

Leva di sgancio  
Release lever



### FC-00-EXPO

Campione dimostrativo del sistema di fissaggio **FAST-CON**<sup>®</sup>, con leva di sgancio (dim. 200x200x58 mm)  
**FAST-CON**<sup>®</sup> fastening system panel sample, with release lever (dim. 200x200x58mm)



# SISTEMI DI FISSAGGIO E INSTALLAZIONE

## Fixing and installation systems

### VTB4.8X9.5.51

Vite autofilettante 4,8x9,5 mm in acciaio inox  
4,8x9,5mm stainless steel self-tapping screw



### Collante

Adhesive





Facile e veloce da installare, **FAST-CON®** garantisce un fissaggio solido ed al contempo removibile. Laddove non sia possibile applicare **FAST-CON®** al pannello o alla struttura direttamente con una vite l'ampia gamma di sistemi di fissaggio **Specialinsert®** è in grado di fornire una soluzione adeguata e compatibile.

Di seguito alcuni esempi:

*Quick and easy to install, **FAST-CON®** ensures a solid and, at the same time, removable fixing. Where it is not possible to apply **FAST-CON®** directly with a screw to the panel or structure, the wide range of **Specialinsert®** fastening systems is able to provide an appropriate and compatible solution. Here are some examples:*



#### **DEFORM-NUT®**

Può essere installato su parti ove non vi sia possibilità di accesso all'interno (ad esempio tubi, laminati, profilati, scatolati, ecc.) e su qualsiasi materiale (alluminio, acciaio, materiali compositi, materie plastiche, ecc.) da uno spessore minimo di 0,5 mm risolvendo così i problemi di filettatura su spessori sottili.

*Can be applied to parts with no access to the inside (for example tubes, sheet metal, box structures, composite materials etc.) and can be fitted to any material (aluminium, steel, fibreglass, plastic and composite materials, etc.) that has a minimum thickness of 0.5mm. Thus, problems involving threading on thin elements are solved.*



**Serie 302**

**Serie 309**

#### **ENSAT®**

Boccola metallica autofilettante, con filettatura interna ed esterna e con fenditure o fori aventi funzione maschiante. Ideale per corpi solidi di varia natura. Dalle materie plastiche alle leghe metalliche passando per il legno, le boccole **ENSAT®** sono ideali per creare sedi filettate con elevate caratteristiche di resistenza ad usura.

*Self-tapping metal insert with internal and external thread and slots or holes having a tapping function. Ideal for solid surfaces of various kinds. From plastics to metal alloys and wood, **ENSAT®** bushes are ideal for creating threaded seats with high wear-resistance characteristics.*

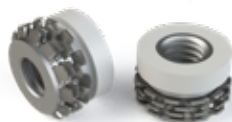

#### **KEEP-NUT®**

Un inserto qualificato e certificato che offre la possibilità di ottenere sedi filettate su lastre ceramiche, di marmo, granito o altro materiale lapideo, materiali compositi, Corian®, HPL, vetro ed altre tipologie di solid surfaces anche di spessore sottile.

*An approved and certified insert used to create threaded seats on slabs in ceramic, marble, granite or other natural stones, composites, Corian®, HPL, glass and other solid surfaces, even thin ones.*



#### **ELIC WOOD**

Boccola autofilettante con filettatura interna ideale per legni teneri, compensati, MDF, truciolati.

*Self-threading bushes designed with a metric internal thread, ideal for softwood, plywood, MDF, chipboard.*



**Specialinsert®** è un'azienda presente nel mondo dei sistemi di fissaggio dal 1974. Nasce per iniziativa di tre tecnici commerciali che, grazie alla loro esperienza nel settore dei fastener, decidono di avviarne la commercializzazione in proprio, affiancandole negli anni l'attività di fabbricazione.

Con tre unità locali, tre depositi, due siti di produzione italiani, un ufficio R&S ed due laboratori prove, **Specialinsert®** è in grado di fornire ai clienti soluzioni sempre più avanzate e adatte ai diversi problemi di fissaggio.

**Specialinsert®** vanta una serie di proposte con soluzioni di fissaggio meccanico adatte a vari settori di applicazione: laminati tubolari metallici, componenti meccanici e plastici, legno, lapidei, nuovi materiali compositi e materiali innovativi quali solid surface, questi ultimi indicati particolarmente per applicazioni su arredi o edili.

**Specialinsert®** was established in 1974 by three sales agents who decided to exploit their experience in the fasteners industry to start up their own retail business. The company later developed and started its own production.

With three local branches, three warehouses, two production plants in Italy, an R&D office and two testing labs, **Specialinsert®** supplies cutting-edge solutions suited to solving the most diverse fastening problems.

**Specialinsert®** offers a series of proposals with mechanical fixing solutions suitable for various application sectors such as: metal tubular laminates, mechanical and plastic components, wood, stone, new composite materials and innovative materials such as solid surface, the latter particularly suitable for applications on furniture or buildings.

## PRODOTTI - PRODUCTS

### LAMINATI METAL SHEETS

Inserti per laminati profilati  
tubolari  
*Inserts for sheet metal  
sections*



### CORPI SOLIDI SOLID PARTS

Inserti per corpi pieni legno  
metallo  
*Inserts for solid wood-metal  
parts*



### PLASTICA PLASTIC

Inserti per materie plastiche  
*Inserts for plastic material*



### COMPOSITI COMPOSITES

Inserti per materiali compositi  
*Inserts for composite  
materials*



Nel costante impegno di migliorare i propri prodotti **Specialinsert®** si riserva il diritto di modificare le caratteristiche tecniche e costruttive senza preavviso: si invita a verificare eventuali aggiornamenti sulle schede tecniche pubblicate sul nostro sito [www.specialinsert.it](http://www.specialinsert.it). Proprietà e diritti del documento sono riservati. Ne è vietata la riproduzione, anche parziale e la diffusione a terzi senza autorizzazione.

**Specialinsert®** is dedicated to the continuous improvement of its products and for this reason reserves the right to make any modifications to its technical or engineering specifications without notice: for the latest updates please refer to the technical data sheets published on our website [www.specialinsert.it](http://www.specialinsert.it). This document is protected by copyright. None of its parts may be reproduced or transmitted to third parties without permission.

**Specialinsert®** è associata UNI, Ente Nazionale di Unificazione. Membro della Commissione Organi Meccanici.  
**Specialinsert®** is UNI associated, National Unification Body. Member of the Mechanical Orders Commission.

**Specialinsert®** al fianco delle università per innovare. **Specialinsert®** alongside universities on innovations.



UNIVERSITÀ  
DEL SALENTO



**SEDE TORINO** | HEADQUARTERS AND EXPORT DEPARTMENT

Via Monfalcone, 144 - 10136 - Torino (Italy) - Tel. +39 011.700.301 R.A. - Fax +39 011.702.947

**FILIALI E STABILIMENTO** | PRODUCTION DEPARTMENT AND BRANCH

Via E. Cialdini 37 - 20161 - Milano (Italy) - Tel. +39 02.646.84.76 R.A. - Fax +39 02.662.002.75

Via E. Pavanello 1 - 30030 - Maerne di Martellago (VE - Italy) - Tel. +39 041.503.01.00 R.A. - Fax +39 041.503.01.10

**WWW.SPECIALINSERT.IT**

INFO@SPECIALINSERT.IT - EXPORT@SPECIALINSERT.IT