



Brakes with a System

Rail Safety



HANNING & KAHL



85 Years of Brake Competence

Rail Safety



HANNING & KAHL has been producing track brakes since 1928. The very serious discussion on the significance of road safety for passengers has always spurred us on the look for new technical solutions, to accelerate their development and to make sure that they are widely applied in practice. Following on from this commitment, the first electro-hydraulic spring-applied brake systems were produced in 1959.

Today the product range in the Rolling Stock Division encompasses a wide selection of highly-sophisticated units for rail-based vehicles: spring-applied actuators, spring-applied brake calipers, brake cylinders, active calipers, hydro-units for multi-stage and stepless brake control, microprocessor-controlled brake controllers, auxiliary release devices, hydraulic levelling systems, sanding systems ... and of course track brakes.

HANNING & KAHL supplies a range of modular brake components which can be combined to form individual solutions for all tram system variants and every requirement. Our modular system offers efficient and safe braking concepts for both 100 % and 70 % low-floor vehicles as well as for high-floor vehicles and metro systems. The individual modules have proven themselves in practical deployment time and time again – providing additional safety. We would be pleased to devise special versions for your particular requirements.



Spring-applied Actuator

Full Force

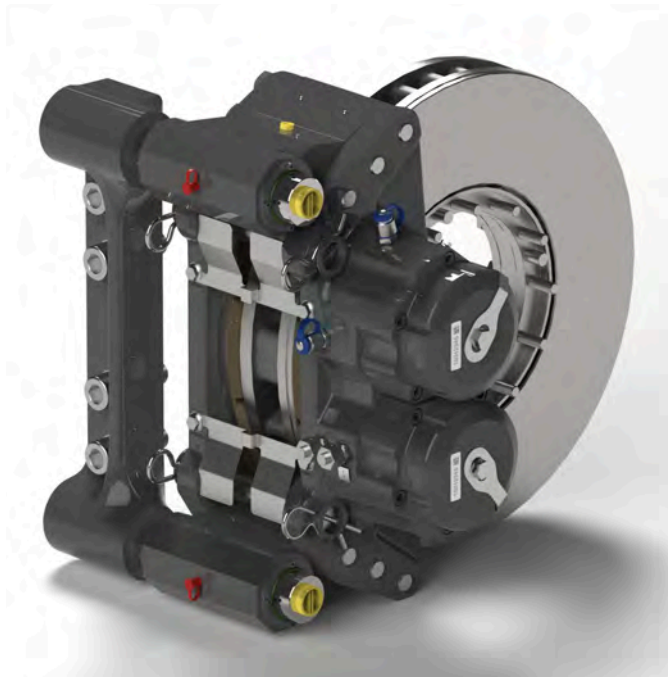

Spring-applied actuator HYS 6xx



Spring-applied actuator HYS 3xx



Spring-applied actuator HYS 15x

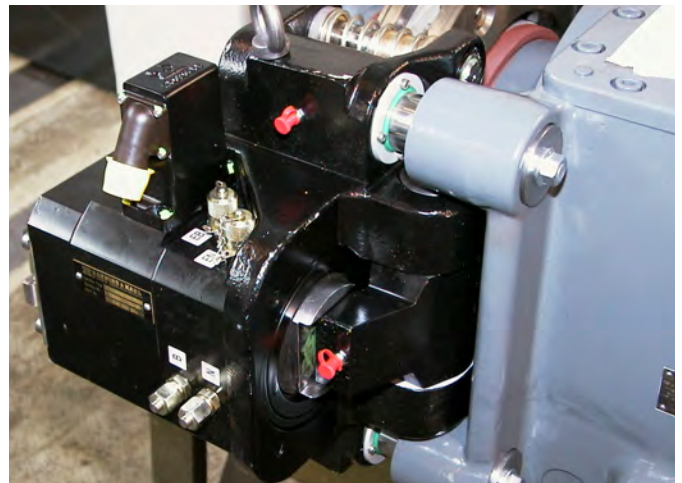

A mounted HYS 351

Spring-applied actuators are the “fail-safe elements” of the safety system in tram vehicles; if the energy supply fails, the braking force is provided with the force of a mechanical spring. The brake caliper design is particularly preferred in low-floor vehicles as there is not enough space for solutions which require brake riggings. Brake calipers are also lighter and they also have lower working strokes which reduces reaction time and the braking distance, too.

Spring-applied brake calipers can either be mounted on the hollow shaft of the gear box, on single-running wheels or on the fast-running motor shaft. No matter where they are mounted, HANNING & KAHL modules perform with optimum efficiency.

Apart from the basic “Brake/Release” function, most spring-applied actuator types are equipped with further functions: a second hydraulic release circuit, automatic slack adjuster and a manual auxiliary release possibility.



Spring-applied actuator HYS 2xx



Spring-applied actuator HYS 1xx



A mounted HYS 202

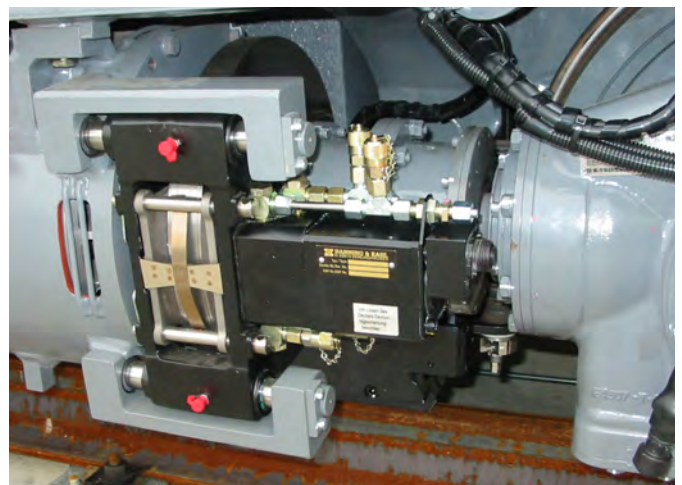

A mounted HYS 101

Spring-applied actuator type	HYS 6xx	HYS 35x	HYS 25x	HYS 15x/HYS 1xx
mounted to/ effective as	motor shaft (high speed) axle brake	hollow gearbox shaft/ axle brake	wheel/single wheel brake	motor shaft (fast-rotating)
force range	14,5 – 35 kN	30 – 50 kN	15 – 30 kN	4 – 11 kN
force transfer	cartridge, direct	cartridge, lever	cartridge, lever	cartridge, direct
slack adjustment	automatic	automatic	automatic	manual/automatic
brake disk (Ø, Breite)	ø bis 640 mm, s bis 100 mm s bis 75 mm	ø 340 – 440 mm, s 60 mm s 60 mm	ø 340 – 440 mm, s 32 – 65 mm s 32 – 65 mm	ø 300 – 350 mm, s 35 mm s 35 mm

Spring-applied Actuators, Primary Suspension

Full Force



Spring-applied actuator HYS 358

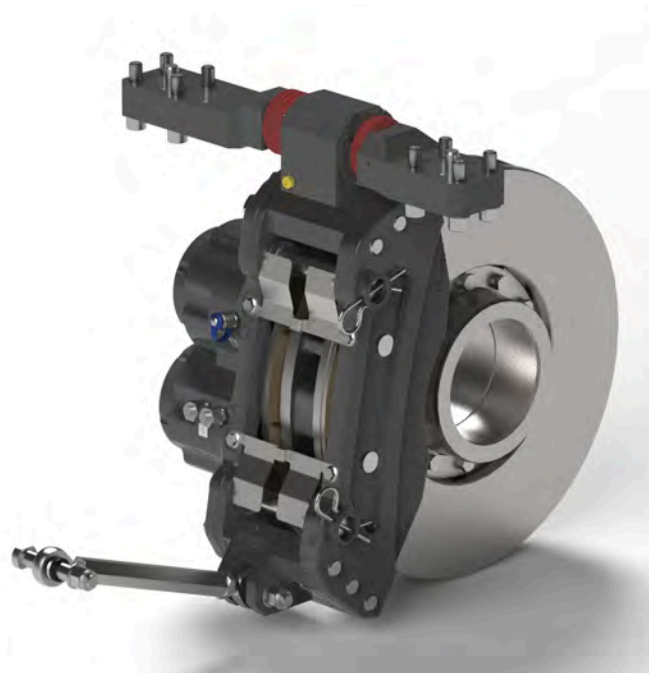

Spring-applied actuator HYS 658

Primary suspension with elastic mounting allows relative movement between brake caliper and brake disc. Forces are transferred onto the bogie or chassis frame by a torque support with maintenance-free swivel heads.



A mounted HYS 358

Spring-applied actuator type	HYS 258	HYS 358	HYS 658
mounted to/ effective as	on primary spring level	on primary spring level	on primary spring level
force range	up to 33 kN	up to 45 kN	up to 66 kN
type	floating caliper with torque support	floating caliper with torque support	floating caliper with torque support
force transfer	cartridge, direct	cartridge, lever	cartridge, lever
slack adjustment	automatic	automatic	automatic
brake disc	ø 380 – 420 mm s 32 – 60 mm	ø 380 – 500 mm s 50 – 75 mm	ø 460 – 520 mm s 75 mm



A mounted HYS 258

Active Brake Caliper

Curbing the costs



Active Brake Caliper HYA 48/56



Active Brake Caliper HYA 26/50

Apart from the spring-applied actuators, HANNING & KAHL also supplies so-called "Active" brakes, where braking force is generated by hydraulic pressure. This favourably-priced type of brake is an appropriate choice whenever the extra safety advantages of the spring-applied actuators are not essential. They are primarily deployed in the brakes in trailer bogies to support the electro-dynamic service brake and maximise brake force whenever emergency braking is called for. Active brakes fit well into the modular concept because they have the same mechanical interface as the spring-applied actuators. It is thus possible to equip the vehicle with the type of brakes driving conditions actually demand without changing the design in any way.

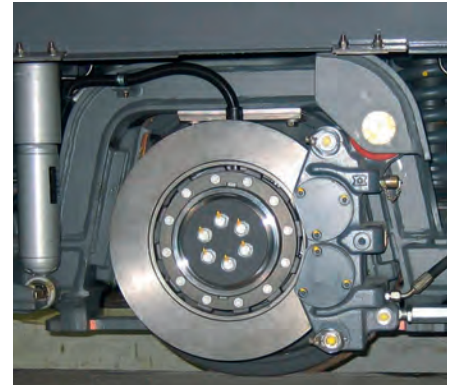

A mounted HYA 48/56

Spring-applied actuator type	HYA 48/56	HYA 26/50
mounted to/effective as	axle - bogie	wheel/single wheel brake
force range	up to 56 kN	25 – 30 kN
type	floating caliper with torque brace	fixed caliper
force transfer	single force cartridge, direct	force cartridges on both sides, direct
slack adjustment	via piston stroke	via piston stroke
brake disc	ø 500 mm, s 60 – 75 mm	ø 340 – 440 mm, s 32 – 60 mm

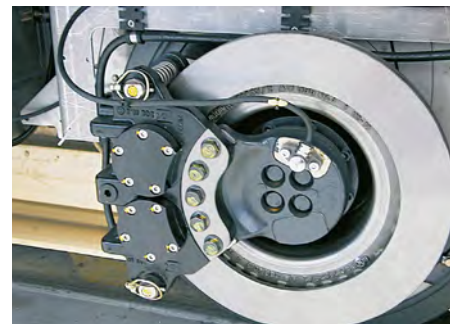

A mounted HYA 26/50

Brake discs

No braking force without friction coefficient



Brake discs

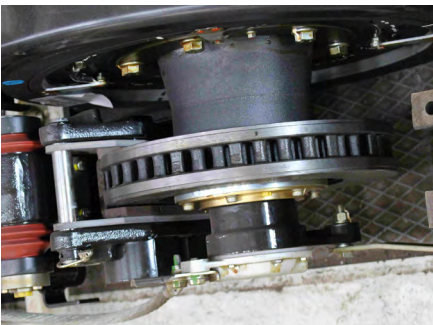

A mounted axle-mounted brake disc



A mounted flange-mounted brake disc



A mounted solid brake disc

HANNING & KAHL brake discs are designed with braking specifications and brake strengths in line with the requirements for urban transport vehicles. Brake discs are exposed to extremely high mechanical and thermic strain.

Customised to the respective bogie/chassis designs and drive concepts, we offer a wide range of brake discs. Brake discs are primarily made from grey cast iron, nodular cast iron or cast from suitable steel alloys, and then machined.

Brake disc type	Place of installation	Dimensions	Comments
Axle-mounted brake discs (BS) ventilated	Wheel set, hollow gearbox shaft	Ø 340mm – 640mm	Consisting of friction ring and hub, split friction rings (optional)
Flange-mounted brake discs (FBS), ventilated	Wheel, stub axle, gearbox flange	Ø 260mm – 460mm	Generally one-piece
Solid brake discs (VBS)	High-speed motor shaft	Ø 300mm – 370mm	Consisting of friction ring and hub

Hydraulic Power Units

Reliability in the Smallest of Spaces

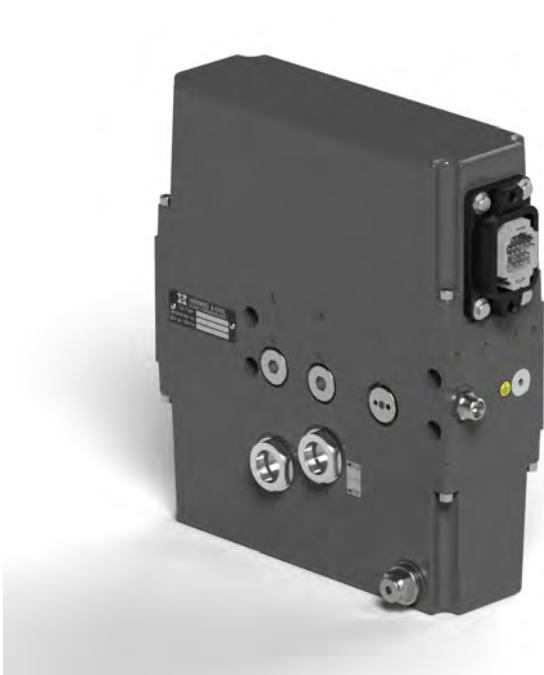

Hydraulic power unit HZY K100



Hydraulic power unit HZY K220

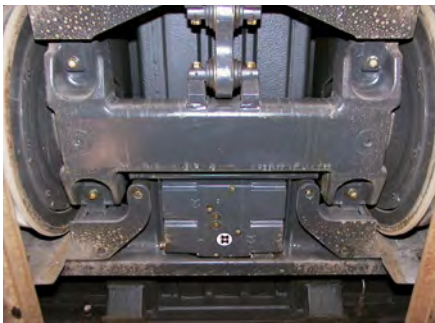

A mounted HZY K100

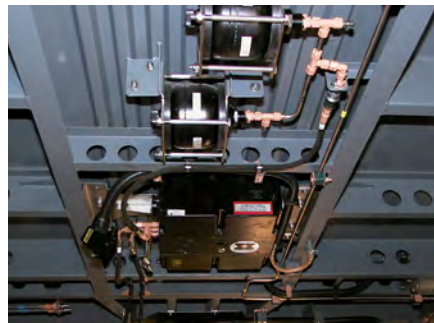

A mounted HZY K140



A mounted HZY K220

Hydraulic power units supplied by HANNING & KAHL reliably control all functions necessary for operation of the braking unit. Our hydraulic power units have a compact design consisting of three parts: tank, manifold and hood. The particularly compact basic device can be fitted on request with convenient or special-purpose functions. These, however, require more installation space. Hydraulic

power units are ideal for deployment in low-floor vehicles where very little space is available. It is possible to activate all the brakes on the bogie by means of a common hydraulic circuit or to control the brakes of each axle individually using separate hydraulic circuits depending on the hydraulic units selected.

Hydraulic power unit type	HZY K100	HZY K140	HZY K220
volume	100 x 250 x 35 mm	140 x 300 x 400 mm	220 x 400 x 500 mm
control function	stepped/(proportional)	stepped/proportional	staged/ proportional/ hydraulic
brake type	active/passive	active/passive	levelling/ spring-applied actuator
controlling unit	train control/HEY-C/BSG	train control/HEY-C/BSG	train control/HEY-C/BSG
mounting place	bogie/car body	(bogie)/car body	(bogie)/car body
pressure range	100 bar	145 bar	170 bar
weight, ca.	15 – 20 kg	30 – 32 kg	50 – 60 kg

Electronic Brake Controllers

The Brake Manager

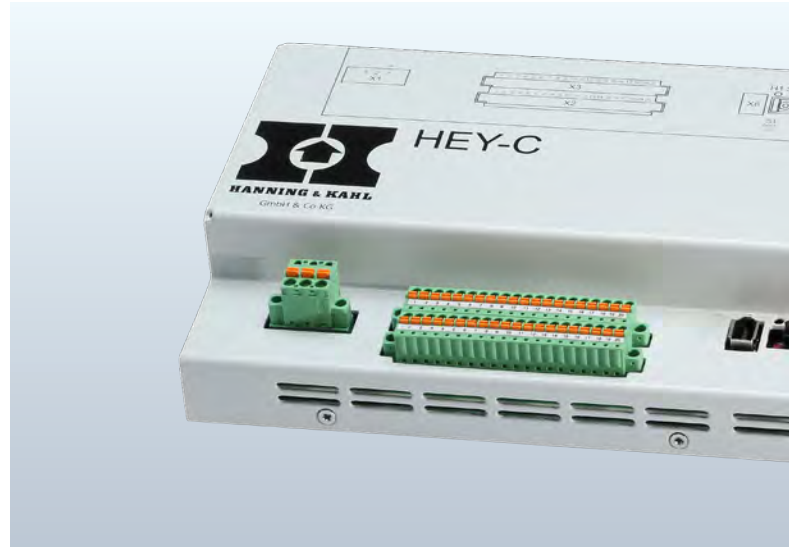

PM – VSS – NSE

Brake controllers form the interface between the HANNING & KAHL braking system and the vehicle controller. The hydraulic power units, and thus the braking force, are activated in line with the project-specific braking matrix. The brake controllers of type HEY und HEY-C deployed by HANNING & KAHL are found in light rail vehicles, trams and driverless metro vehicles.

The controllers can implement certain functions with SIL2 in accordance with EN 50657 / EN 50128 (software) and EN 50129 (hardware), and also comply with standard rail-application norms EN 50155, EN 50121-3-2 and EN 61373.

With its very compact design, the brake controller of type HEY-C can also be easily integrated into small spaces, regardless of installation position. The electric interface with various analogue and digital inputs and outputs is sufficiently dimensioned for most applications. Thanks to its modular construction, the brake controller of type HEY offers a higher number of inputs and outputs. This means that very extensive interfaces can be realised. Special functions, for example wheel-slide protection or communication of vehicle speed, can be implemented via the software.

Brake controller	Semi-conductor contactor PM	Valve control stage VSS	Control electronics NSE
equipment	analogue electronics	analogue	micro-processor
mech. design	clip-on case	clip-on case	clip-on case
control	ON/OFF	3-stepped or proportional output	programmable
application	DC-motors with 24 V up to 40 A	stepped or proportional brake control without logic operations	stepped or proportional brake control with simple logic operations
function	wear-free switch-on and switch-off	braking/releasing	braking/releasing parameter – dependent simple logic operations
certification			



Brake controller HEY-C



Brake controller HEY

To extend connectivity, both control types can be equipped with different bus systems (CAN, MVB and Ethernet). Software download and extensive diagnosis are usually effected via Ethernet or CAN.

The VSS valve control stage and the NSE control electronics are designed for less demanding tasks in braking management. They activate the brake in analogue/single-channel manner per microprocessor. The PM (electronic semi-conductor contactor) component can switch on/off DC motors with a power up to 1KW wear-free.



A mounted HEY-C

Brake controller HEY-C	Brake controller HEY
two-channel micro-processor	two-channel micro-processor
housing	19" rack, 42 or 84 HP
program-controlled	programmable
stepped or proportional brake control with complex logic operations	stepped or proportional brake control with complex logic operations
braking/releasing parameter-dependent complex logic operations weight evaluation	braking/releasing parameter-dependent complex logic operations speed sensor evaluation
CAN bus connection	wheel slide control
MVB bus connection	weight correction
Ethernet bus connection	optional vehicle bus connection
	CAN bus connection
	MVB bus connection
	Ethernet bus connection
SIL 3	SIL 2



A mounted HEY

Elektro-Hydraulic Modules

Plug & Play

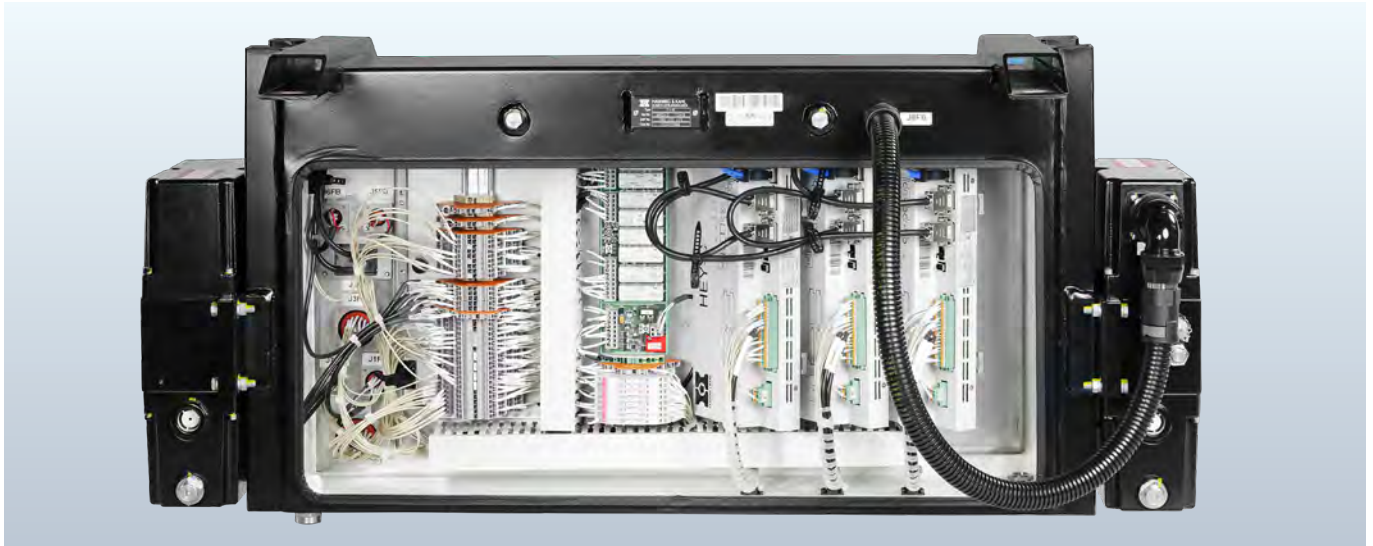

Electro-Hydraulic-Modul

HANNING & KAHL has added an electro-hydraulic module for hydraulic brake activation to its product portfolio designed especially for the use of hydraulic brake systems in metro vehicles. The ready-to-install, electro-hydraulic module comprises hydraulic pressure generation, pressure regulation and electric control in one. The wiring between the electronic brake control unit and the hydraulic system which usually takes place in the vehicle is already integrated. In basic version, the electro-hydraulic module is composed of proven standard components in modular design. Further functions can also be integrated into the electro-hydraulic module in line with technical braking requirements.

The Advantages for You:

- substantial minimisation of vehicle wiring
- straightforward mounting of a tried and tested module
- easy commissioning
- good accessibility to all individual modules/standard components
- high availability with simple and fast replacement of individual modules/standard components
- minor maintenance and simple repair by straightforward replacement of individual modules

EHM Electro-hydraulic-module

Number of activated bogies/wheelsets	Independent electric/hydraulic activation of 2 bogies
Voltage	DC 24 V (train control wire DC 48 V)
Communication interface	CAN/MVB/Ethernet
Dimensions	1100 x 510 x 500 (L x W x D in mm)
Weight	ca. 90 kg
Hydraulic activation	Proportional per bogie
Housing protection	IP65
Permissible system pressure	160 bar



A mounted EHM

Sanding System

GripMaster®

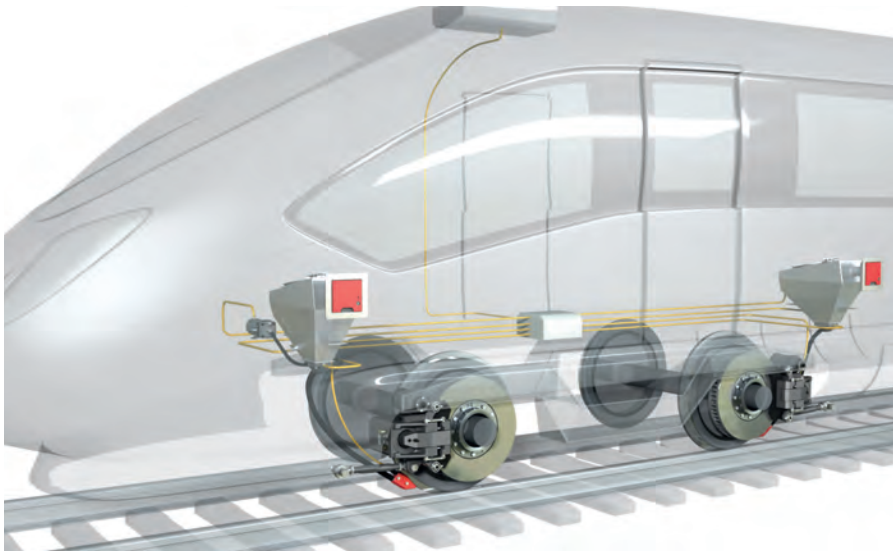

GripMaster®

In rail vehicles, sanding systems are safety-relevant systems which ensure safe braking and acceleration. They increase the adhesive friction between wheel and rail in order to improve power transfer. Working closely together with manufacturers and operators, we develop innovative and reliable sanding systems for rail vehicles with modular structure and customized design. From project planning to design engineering, development to manufacture and sales, users get everything from one source.

HANNING & KAHL does not use any moving components which are in contact with abrasive sand - this is a major leading edge for the sanding system. In addition, compact design and low LCC costs are decisive arguments for users.

Further options:

- Continuous measurement of the remaining sand volume by ultrasonic level sensor in the sand box.
- Central pneumatic supply throughout the rail vehicle by replacement of the compressor with a pneumatic unit.
- Control of the sand quantity depending on vehicle speed by pulse-width-modulated operation of the valves in the dispensing units*
- Diagnosis and communication per CAN, MVB or Ethernet bus.*

* in conjunction with the HANNING & KAHL sanding control unit SCU

GripMaster®	
Sand mass flow variable	up to 1,200 g/min
Reaction time with a meter conveying distance	< 500 ms
Deployment temperature range	-30 to +50 °C
Sand box volume	Customer-specific

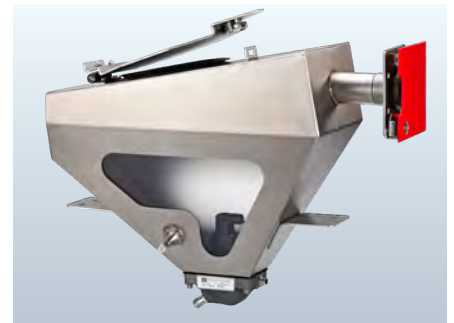

Sand box



Sanding outlet



Sanding nozzle



Compressor

Auxiliary Release Devices

When Nothing Moves



Auxiliary Release Device HZY NL

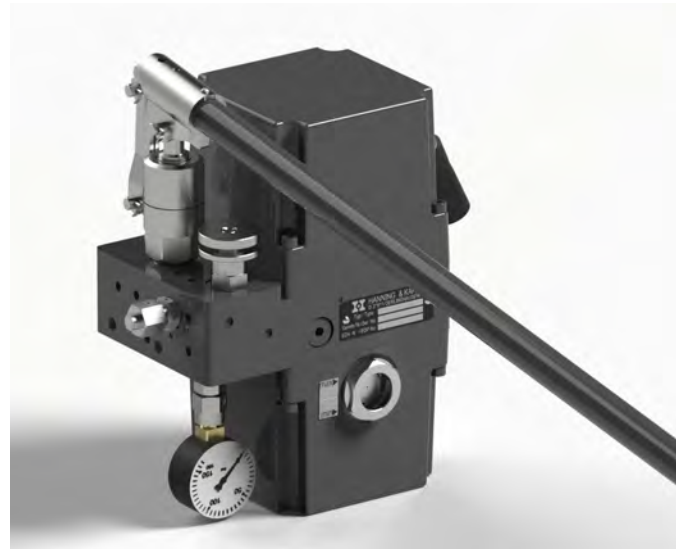

Auxiliary Release Device HZY NL/HP

Spring-applied actuators brake the vehicle after an energy failure thus providing an indispensable safety instrument. After braking, however, there is a slight technical problem: the vehicle cannot be moved unless there is hydraulic pressure in the service release circuit. HANNING & KAHL has designed auxiliary release devices for this particular application. These devices can build up pressure in the actuator's second hydraulic circuit independently of the service release circuit. The brake can be released with this pressure allowing the vehicle to be moved again. An auxiliary release device can be deployed to release all the brakes on a tram or just the brakes of a particular bogie depending on the vehicle design.



A mounted HZY NL/HP

Auxiliary release device-type	HP	HZY NL	HZY K100 NL/HP
equipment	stationary hand pump	electrically propelled small hydraulic power unit	electrically propelled hydraulic power unit in connection with hand pump
mech. design	frame type	compact	compact
mounting location	car body (driver's cab)	bogie	car body
application	manual release per car or per bogie	electrical release per bogie	manual or electronic release per car
functions	manual op. release manual op. braking electronic. op. braking	electric. op. release electric. op. braking	manual op. release electric. op. release manual op. braking electric. op. braking

Track brakes – Solid-block magnets

For Extra Safety



Track brakes – Solid-block magnets



A mounted track brake HS 6x

The brake force which is obtained via the frictional contact between wheel and rail is often not sufficient. By way of support and also in compliance with statutory requirements, the individual bogies/chassis of the vehicles are additionally equipped with track brakes.

Track brakes are mounted between the two wheels. In design and size, they must fit into the space available on the bogie/chassis. HANNING & KAHL has been developing and producing innovative track brake solutions for effective integration into vehicles for more than 80 years.

Dependent on design, length and attachments, HANNING & KAHL offers a wide range of track brakes: varying from track brakes with a length of ca. 480 mm and an adhesive strength of 35 kN to a length of 1,300 mm and an adhesive strength of ca. 90 kN.

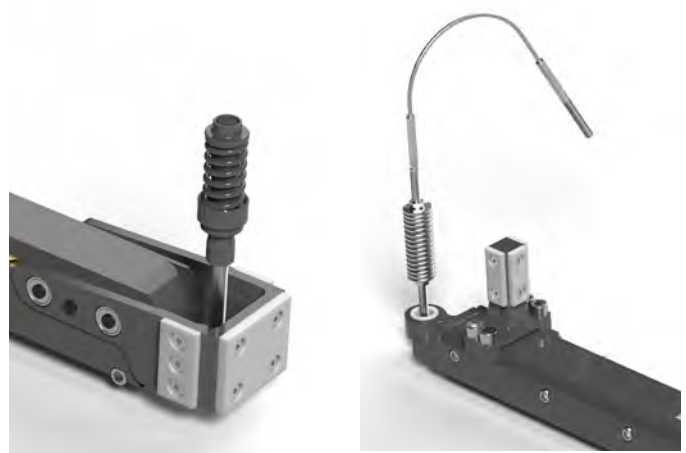

Pushing track brake link device, pressure-spring suspension

Pulled track brake link device, steel cable suspension

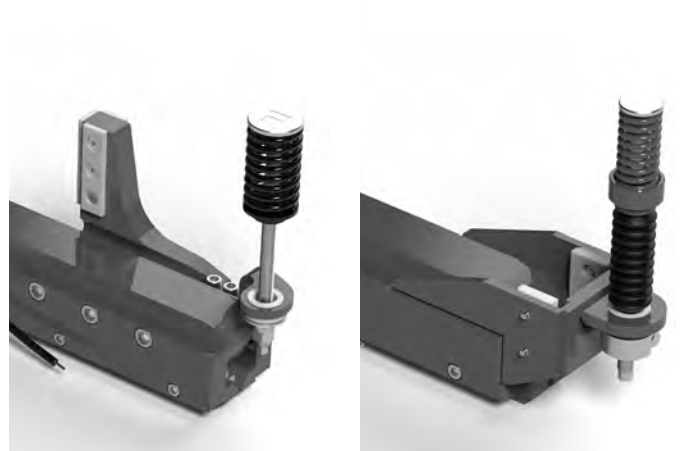

Side track brake link device, pressure-spring suspension

Front pulled track brake link device, pressure-spring suspension

Hydraulic Levelling

Barrier-free Boarding and Alighting

To avoid differences in car body height and hazardous gaps between tram and platform when passengers are boarding and alighting, HANNING & KAHL has added a system for levelling tram cars to its product portfolio. The first series vehicles have now been equipped with the system and are in successful passenger operation.

The levelling system ensures that car bodies are kept at a defined level in all operating states and circumstances. Several functions are integrated such as automatic adjustment of wheel tyre wear, compensation of the primary springs in the bogie, as well as levelling of changes in height (caused by passenger change). Position, travel and pressure sensors are used to control and monitor levelling so that wayside and vehicle-dictated clearance limits are kept, thus guaranteeing operational safety at all times.

Below you find an overview of all operating modes:

- Regulation of car body height corresponding to load status (only when vehicle is standing still)
- Freezing of height level for the run between stop stations
- Compensation of wheel tyre wear and relaxation of primary suspension

In general, the overall system consists of the following five main components:

1. Hydraulic unit (HZY) for generation of hydraulic pressure in the system. The device can operate the mechanical brake at the same time.
2. Valve control unit (HVU) which contains the valves for control of the lift cylinder and also pressure sensors for internal monitoring.
3. Lift cylinder (HYHZ) for raising and lowering the car body modules. Position sensors integrated in the lift cylinder control and monitor position.
4. Electronic Control Unit (LCU) for control of the valves and for continuous monitoring of differences in height between the individual car bodies. There is a hardware interface and two independent bus systems for extensive data exchange.
5. Position sensors (DS) for control and monitoring of the relative position between car body and bogie.



Hydraulic Levelling

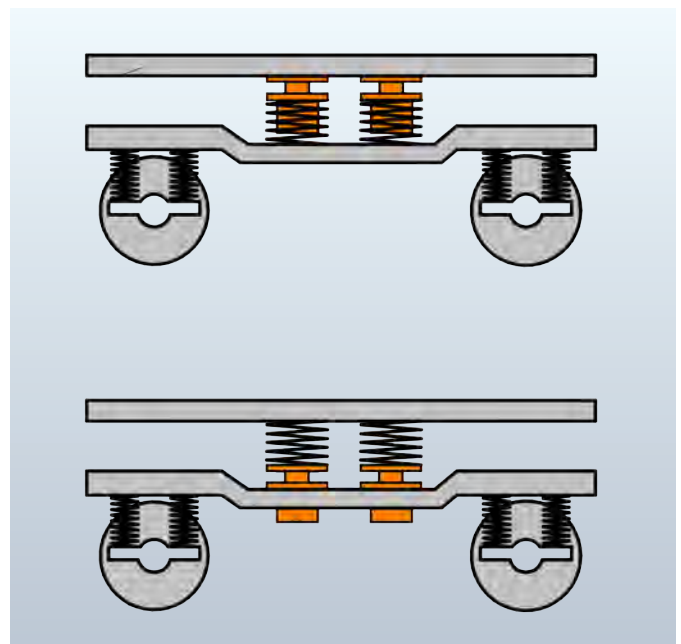

Different possibilities of installing the lift cylinder in the bogie

Hydraulic Levelling	
Number of lift cylinders per bogie	2 or 4
Vertical static force per lift cylinder	ca. 50 kN
Max. cylinder stroke	85 mm
Cylinder stroke tolerance	± 1 mm
Pemissible system pressure	160 bar

Hydraulic Levelling Systems

Barrier-free Boarding and Alighting

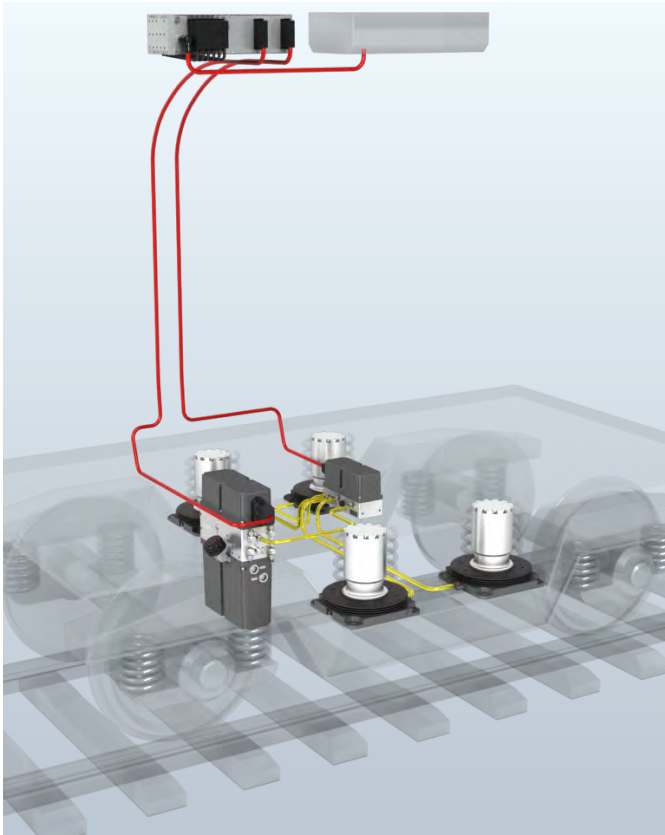

To avoid differences in car body height and hazardous gaps between tram and platform when passengers are boarding and alighting, HANNING & KAHL has developed a system for levelling tram cars.

The levelling system is illustrated here with the example of a three-car vehicle whose car bodies rest on three bogies. Two lift cylinders (HYHZ) on each bogie side are hydraulically activated via a valve control unit (HVU). The necessary pressure is provided by a hydraulic power unit with enlarged tank and external pressure accumulator which also supplies the hydraulic brake. Position, travel, and pressure sensors forward their signals to the electronic control unit (LCU) which passes the resulting commands to the valve control unit and thus closes the circle.



The following objectives have been met with the levelling system:

- Regulation of car body height corresponding to load status (only when vehicle is standing still), then freezing of height level for the run between the stations
- Compensation of wheel tyre wear and setting of primary and secondary suspension.

With the HANNING & KAHL levelling system, you are ideally prepared for the future requirements of DIN 18040 (max. permissible difference in height between vehicle and platform of 50 mm).



100 % Low-Floor Vehicles

System Variant Urbos

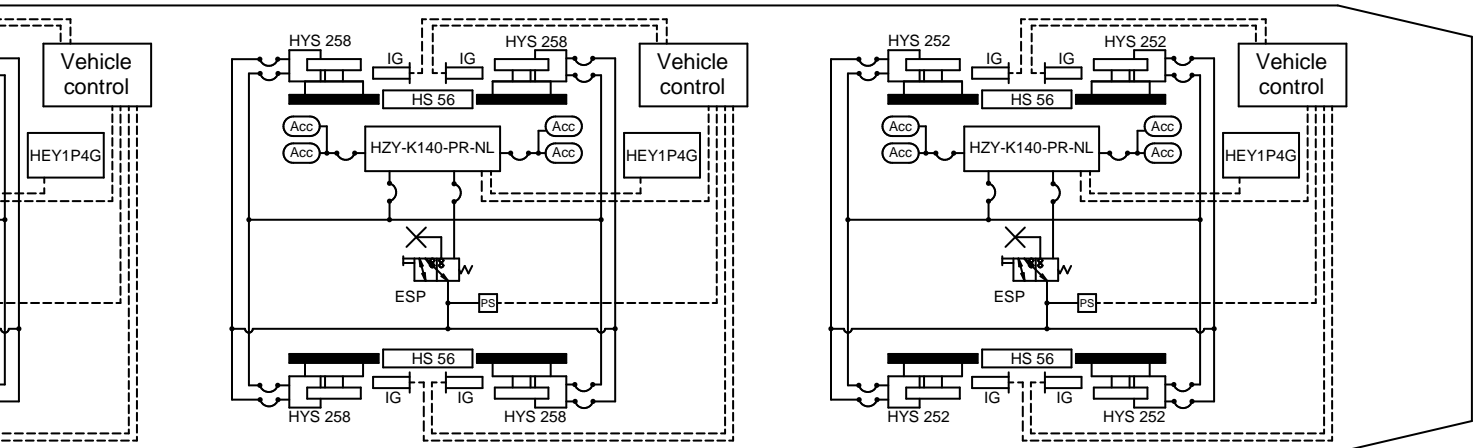

The 7-part multi-articulated vehicle has 3 motor bogies and one trailer bogie.

The motor bogie has a spring-applied actuator HYS 252 on each drive wheel, which is controlled by a hydraulic power unit HZY K140-PR-NL with external pressure accumulator. The spring-applied actuators have two independent hydraulic circuits: the service circuit and the auxiliary release circuit. The hydraulic power unit supplies the proportional pressure for the service circuit, and also the pressure for the auxiliary release circuit via which all 4 spring-applied actuators of the bogie concerned can be released in the event of a malfunction. The HEY-C brake control unit ensures proportional activation of the hydraulic power unit and error monitoring.

Each wheel of the trailer bogie has a spring-applied actuator of type HYS 258. Here, too, the four spring-applied actuators are proportionately controlled by a hydraulic power unit HZY K140-PR-NL with external pressure accumulator. In interaction with 4 speed sensors, brake control unit HEY 2P/4G implements the necessary slide protection.



In the event of a malfunction, the spring-applied actuators can be released using a hand pump which is operated from the inside of the car via the independent auxiliary release circuit. A mechanical release possibility allows opening of the spring-applied actuator for workshop purposes.

Two track brakes per bogie round off the braking system.



100 % Low-Floor Vehicles

System variant Avenio TZ

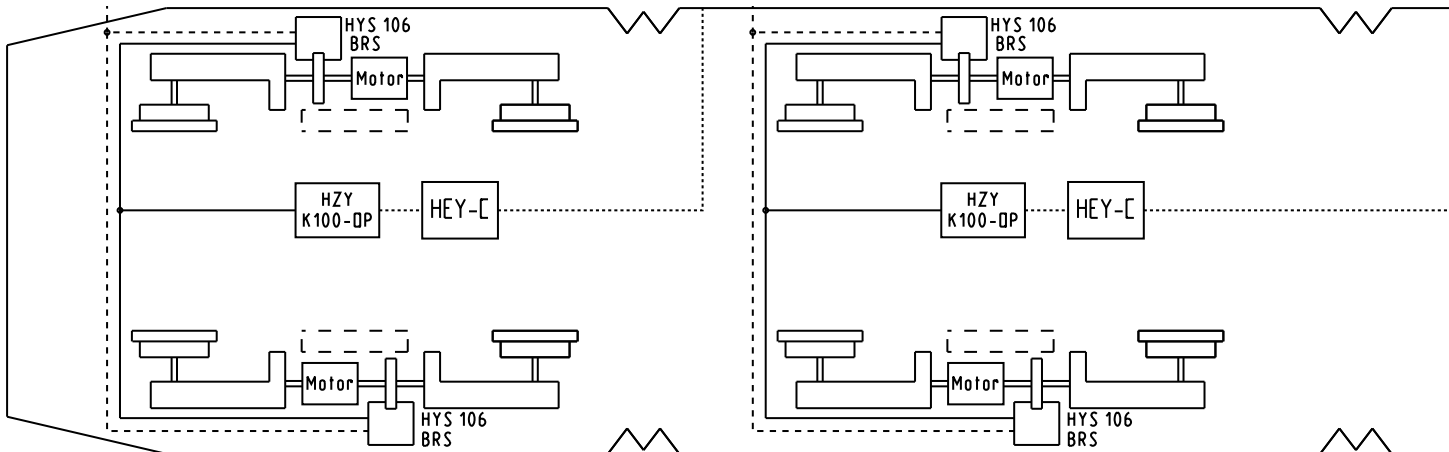

The vehicle consists of 4 car bodies which rest on three motor bogies and one trailer bogie.

Each of the motor bogies is equipped with a HYS 106 spring-applied actuator which is positioned between motor and gearbox. Infinitely variable activation of the two spring-applied actuators of a motor bogie is effected via a hydraulic unit HZY K100-DP which triggers train control (e-supplier) via the electronic brake control unit HEY-C. A pressure sensor in the hydraulic unit reports the pressure in the service circuit. The position of the spring-applied actuator in the direction of the vehicle exterior makes for easy maintenance.

In the trailer bogie, each idle wheel is braked by active brake caliper HYA 26/50. The four brake calipers are activated by hydraulic unit HZY K100-AP with external pressure accumulator. In interaction with four speed sensors, the electronic brake control unit provides the necessary wheel-slide protection.

Two HS 70 track brakes per bogie, each with an adhesive strength of 70 kN, provide even greater deceleration in the event of emergency braking.

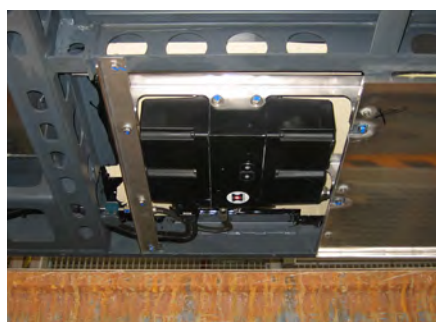

100 % Low-Floor Vehicles

System Variant ForCity

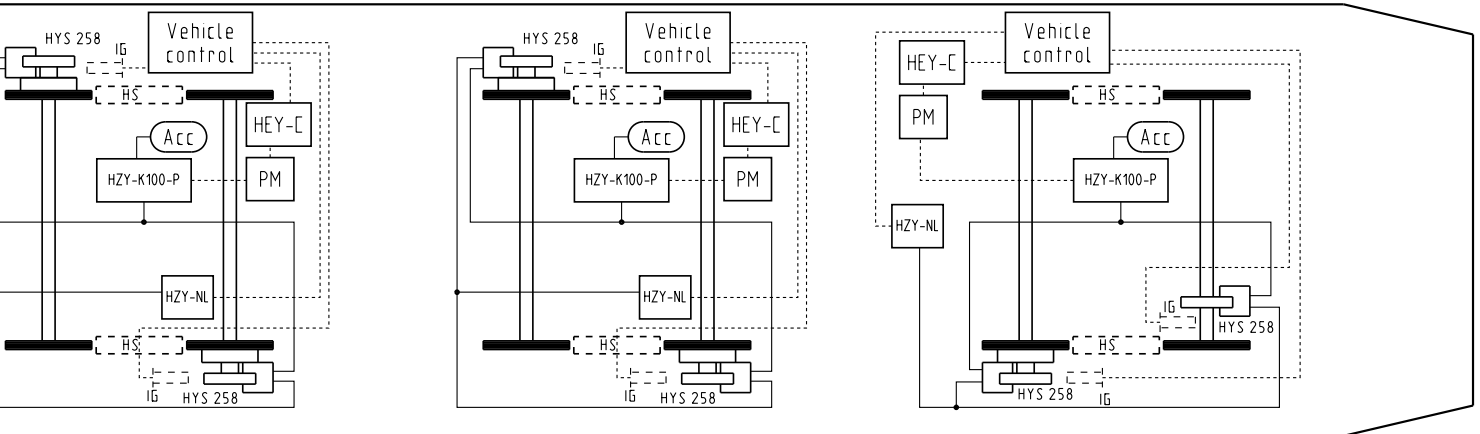

Vehicle length can be determined via the number of passenger modules and the number of motor and trailer bogies. Whereby motor and trailer bogies have the same braking equipment.

Each bogie is equipped with two HYS 258 spring-applied brake calipers which act on internally ventilated flange brake discs or shaft brake discs. Spring-applied brake caliper HYS258 is a direct-acting "one-cartridge brake caliper".

The brake calipers are attached to the bogie frame by means of elastic suspension. Elastic suspension means that elastic bearing enables relative movement between brake caliper and brake disc. The brake caliper is supported by a torque arm on the bogie frame/motor housing.

Hydraulic activation follows via a HZY-K100-PR hydraulic unit which is connected to an external pressure accumulator. A HEY-C brake control unit is used for electric activation. The hydraulic auxiliary release is realised via an independent second hydraulic circuit by a HZY-NL auxiliary release hydraulic unit.

Each spring-applied brake caliper can also be auxiliary released mechanically from the exterior of the vehicle. Two HS 60 solenoid rail brakes which work independently of the friction between wheel and rail are also integrated.

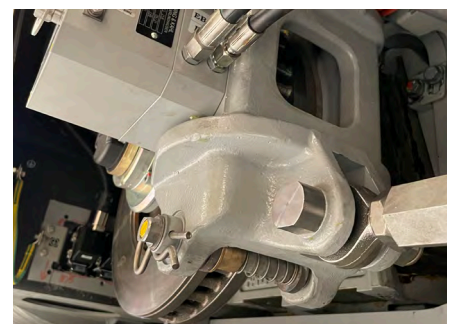
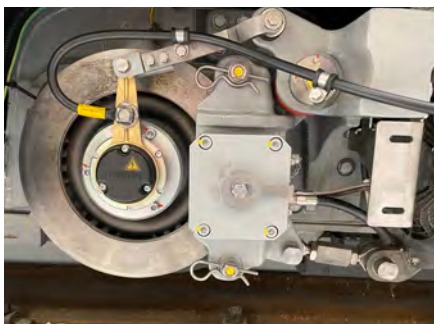

System Metro

System Variant SkyTrain

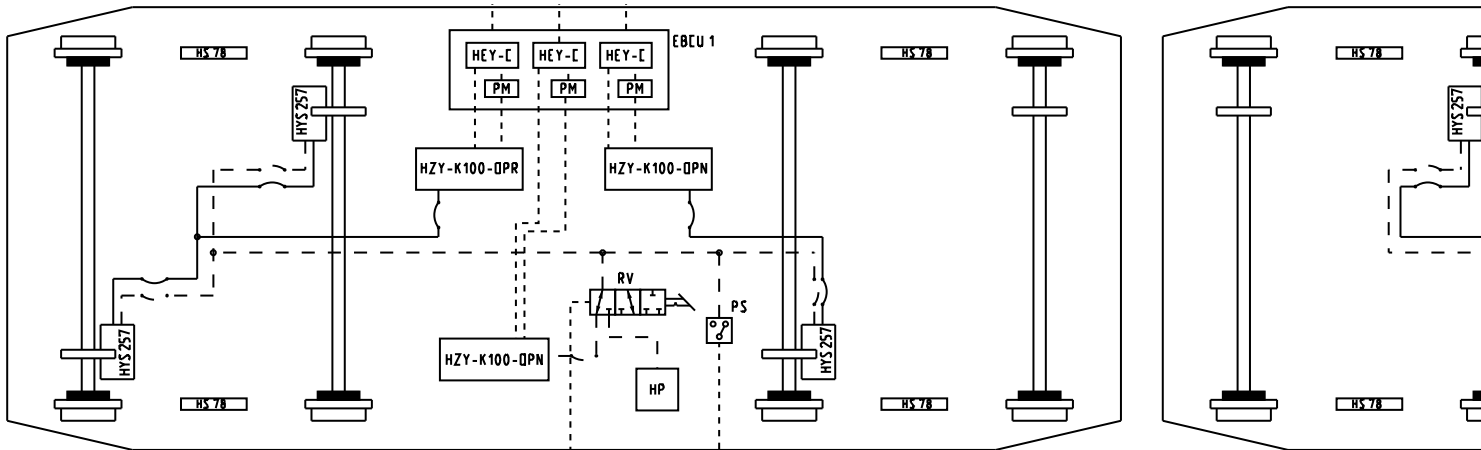

A metro vehicle or driverless system generally consists of several car bodies. We will look at the hydraulic braking system of a single car body with two bogies.

Each bogie is equipped with a spring-applied brake caliper HYS 257 per axle. HYS 257 is a floating mounted "one-cartridge brake caliper" with direct impact. The brake caliper is directly attached to the axle bearing via a bracket and acts on an internally vented axle-mounted brake disc. Each bogie has two independent hydraulic circuits: a service circuit and an auxiliary circuit for potential malfunctions. An electro-hydraulic module (EHM) positioned underneath the car body performs proportional, hydraulic activation of the spring-applied brake calipers on individual bogie basis. The modular, ready-to-install, electrohydraulic module contains the entire hydraulic brake activation equipment, consisting of hydraulic pressure generation, pressure regulation and electric brake control. All components are electrically controlled and monitored via three independent brake control units of type HEYC which are integrated into the EHM module. Braking and electric control functions performed by the EHM module:

- Service brake, emergency brake and parking brake
- Wheel-slide protection, load registration, blending, diagnosis and monitoring



In the event of a malfunction of the main hydraulic system, the spring-applied actuators of both bogies can be released by a separate auxiliary hydraulic power unit via an independent hydraulic circuit. A second manual auxiliary release possibility is provided by a transportable hand pump via a ball valve which is integrated between auxiliary hydraulic power unit and spring-applied actuators. To increase deceleration in emergency and safety braking, both bogies have track brakes.



Brakes with a System

Rail Safety

HANNING & KAHL brake systems are the outcome of a successful symbiosis of economic series production and customized design. The results are practical and reliable integrated solutions from one source, which mean quick returns on investment for operators – one reason why our products are at home all over the world. The fundamental advantages of HANNING & KAHL brake systems will convince you:

- A wide product range for all requirements
- Fulfilment of all specifications of BOStrab, VDV guidelines, DIN und CENELEC
- Detailed quality control and documentation

With HANNING & KAHL you have a committed, recognised and reliable partner at your side. We offer you:

- Practically-oriented workshops
- Testing and service equipment for professional maintenance and upkeep
- 24-hour on-call service – we are always at your disposal!
- Customised service solutions

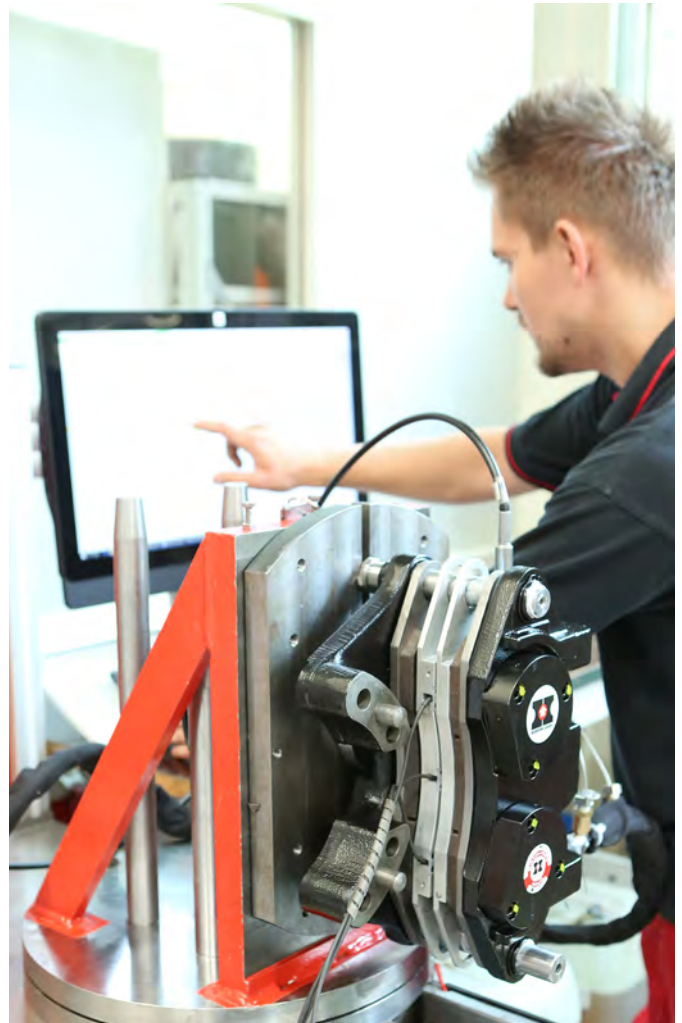

Developing the Future Together

Adelaide	Ghent	Melbourne	Vancouver
Amsterdam	Gera	Milan	Vienna
Antwerp	Glasgow	Miskolc	Vitoria
Ankeng	Gmunden	Montpellier	
Arad	Gorzow	Mülheim	Warsaw
Arrgau	Göthenburg	Munich	Wuhan
Athens	Graz		Wuppertal
Augsburg	Guangzhou	Nantes	
		Nordhausen	Zagreb
Barcelona	Halle/Saale	Norrköping	Zermatt
Basel	Hanover	Nottingham	Zürich
Berlin	Halberstadt	Nuremberg	Zwickau
Bern	Hancheng		
Bielefeld	Hebei	Odessa	
Birmingham	Heidelberg	Olsztyn	
Bonn	Helsinki	Okayama	
Böblingen	Hiroshima	Oradea	
Bratislava	Huai'an		
Braunschweig	Huangpu	Paramatta	
Bratislava		Porto	
Bremen	Iasi	Posen	
Brno	Istanbul	Potsdam	
Bucharest			
Budapest	Jena	Qatar	
Bursa	Jerusalem		
		RandstadRail	
Calgary	Kassel	Rennes	
Canberra	Katowice	Roissy	
Cardiff	Kayseri	Rome	
Changchun	Kiew	Rostock	
Chicago	Kocaeli	Rotterdam	
Chemnitz	Konya		
Chengdu	Kopenhagen	Saarbrücken	
Chorzow	Krakow	Saragossa	
Cleveland	Krefeld	Salt Lake City	
Cluj	Kuala Lumpur	Salzgitter	
		Samsun	
Danhai	Lusanne	San Diego	
Danzig	Lemberg/Lviv	Santos	
Darmstadt	Leipzig	Schönbrunnbahn	
Denver	Liège	Shenyang	
De Lijn	Liepaja	Shenzhen	
Dortmund	Lille	St. Etienne	
Dresden	Linz	Sydney	
Duisburg	Lisbon		
	Lodz	Taipei	
Echizen	Lucerne	Takaoka	
Edmonton	Ludwigshafen	Tallinn	
Erfurt	Lugano	Tampere	
Eskisehir	Lund	The Hague	
	Lüttich	Timisoara	
Frankfurt/Main		Toulouse	
Freiburg	Magdeburg	Toyama	
Fukui	Malaga	Turin	
	Mannheim		
Galati	Marseille	Uiejongbu	
Gdansk	Matterhorn	Ulm	
Geneva	Mauritius	Utsunomiya	

Brakes with a System

Rail Safety



Hanning & Kahl GmbH & Co. KG
Rudolf-Diesel-Straße 6 | 33813 Oerlinghausen | Germany
Phone +49 5202 707-600 | Fax +49 5202 707-629
info@hanning-kahl.com | www.hanning-kahl.com

08/2024